

Instructions and Parts List

3M-Matic™ Accuglide™ 3

Type 10800

Upper and Lower High Speed Taping Heads 3 Inch

Serial #: _____
For reference, record machine serial number here.

Important Safety Information

BEFORE INSTALLING OR OPERATING THIS EQUIPMENT
Read, understand and follow all safety and operating instructions.

Spare Parts

It is recommended you immediately order the spare parts listed in the “Spare Parts/Service Information” section. These parts are expected to wear through normal use, and should be kept on hand to minimize production delays.

Replacement Parts and Service Information

To Our Customers:

This is the 3M-Matic™/AccuGlide™/Scotch® equipment you ordered. It has been set up and tested in the factory with Scotch® Tapes.

Included with each machine is an Instructions and Parts List manual.

Technical Assistance / Replacement Parts and Additional Manuals:

For technical assistance, contact our help line.

Provide the customer support coordinator with the model/machine name, machine type, and serial number that are located on the identification plate

(For example: Model - Accuglide 3 (3inch) Taping Head - Type 10800 - Serial Number 13282).

To order replacement parts, contact us:

CSPD division of Combi Packaging Systems LLC.

5365 East Center Dr. N.E.

Canton, OH 44721

1-800-344-9883

e-mail: CSPD-CSR@combi.com

www.combi.com

Identification Plate

3M 3M Company St. Paul, MN 55144 USA	Part Number	3M-Matic™ For Commercial Use Only			
	Model	Year	Ampere	Watt	
Type	Serial Number	Volt	Hertz	Phase	

Replacement Parts and Service Information *(continued)*

To Our Customers:

This is the 3M-Matic™/AccuGlide™/Scotch® equipment you ordered. It has been set up and tested in the factory with Scotch® tapes.

Included with each machine is an Instructions and Parts List Manual.

Service, replacement parts, and additional manuals available direct from:

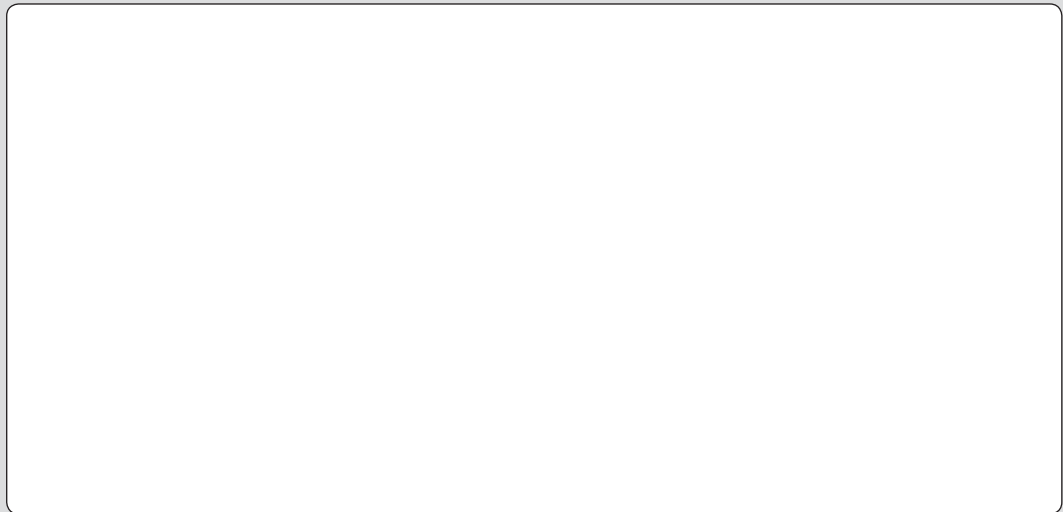

Order parts by part number, part description, and quantity required. Also, when ordering parts or additional manuals, include model/machine name, machine type, and serial number that are located on the identification plate.

Table of Contents - Manual 2: Accuglide 3 High Speed - 3 inch

(Upper and Lower Taping Heads)

Accuglide 3 High Speed Taping Head Manual - 3 inch	Page
Cover Page	
Replacement Parts and Service Information	i – ii
Table of Contents	iii – v
Equipment Warranty and Limited Remedy.	vi
Intended Use	1
Taping Head Contents / How to Use Manual	3
Important Safeguards.	4-5
Specifications	6-7
Dimensional Drawing	7
Installation	8
Receiving and Handling	8
Installation Guidelines	8
Tape Leg Length.	8
Tape Width Adjustment	8
Operation	9-11
Tape Loading – Upper Taping Head	10
Tape Loading – Lower Taping Head.	10-11
Maintenance	12-13
Blade Replacement	12
Blade Guard	12
Blade Oiler Pad	12
Cleaning	13
Applying/Buffering Roller Replacement	13
Adjustments	14-15
Tape Latch Alignment	14
Tape Drum Friction Brake	14
Applying Mechanism Spring	15
One-Way Tension Roller	15
Tape Leg Length.	16
Leading Tape Leg Length Adjustment	16
Changing Tape Leg Length - 70 to 50 mm [2-3/4 to 2 Inch]	16
Troubleshooting Guide	17-18
Spare Parts/Service Information	19
Recommended Spare Parts	19
Replacement Parts and Service.	19-20
Replacement Parts Illustrations and Parts List.	21-End of Manual

Warranty

Warranty

Equipment Warranty and Limited Remedy: THE FOLLOWING WARRANTY IS MADE IN LIEU OF ALL OTHER WARRANTIES, EXPRESS OR IMPLIED, INCLUDING, BUT NOT LIMITED TO, THE IMPLIED WARRANTY OF MERCHANTABILITY, THE IMPLIED WARRANTY OF FITNESS FOR A PARTICULAR PURPOSE AND ANY IMPLIED WARRANTY ARISING OUT OF A COURSE OF DEALING, A CUSTOM OR USAGE OF TRADE:

3M sells its **3M-Matic™ Accuglide 3 Taping Head Type 10800** with the following warranties:

1. The Taping Head blade, springs and rollers will be free from defects in material and manufacture for ninety (90) days after delivery.
2. All other Taping Head parts will be free from defects in material and manufacture for three (3) years after delivery.

If any part is defective within this warranty period, your exclusive remedy and 3M's and seller's sole obligation shall be, at 3M's option, to repair or replace the part. 3M must receive actual notice of any alleged defect within a reasonable time after it is discovered, but in no event shall 3M have any obligation under this warranty unless it receives such notice within five (5) business days after the expiration of the warranty period.

All notices required hereunder shall be given to 3M solely through the 3M-Matic™ Help line. To be entitled to repair or replacement as provided under this warranty, the part must be returned as directed by 3M to its factory or other authorized service station designated by 3M. If 3M is unable to repair or replace the part within a reasonable time after receipt thereof, 3M, at its option, will replace the equipment or refund the purchase price. 3M shall have no obligation to provide or pay for the labor required to remove any part or equipment or to install the repaired or replacement part or equipment. 3M shall have no obligation to repair or replace those parts failing due to normal wear, inadequate or improper maintenance, inadequate cleaning, non-lubrication, improper operating environment, improper utilities, operator error or misuse, alteration or modification, mishandling, lack of reasonable care, or due to any accidental cause.

Limitation of Liability: Except where prohibited by law, 3M and seller will not be liable for any loss or damage arising from this 3M equipment, whether direct, indirect, special, incidental, or consequential, regardless of the legal theory asserted, including breach of warranty, breach of contract, negligence, or strict liability.

Note: The foregoing Equipment Warranty and Limited Remedy and Limitation of Liability may be changed only by a written agreement signed by authorized representatives of 3M and seller.

AccuGlide™, Scotch™, and 3M-Matic™ are Trademarks of 3M, St. Paul, Minnesota 55144-1000

Intended Use

The intended use of the AccuGlide™ 3 Upper and Lower Taping Heads - 3 inch is to apply a “C” clip of Scotch® pressure-sensitive film box sealing tape to the top and/or bottom center seam of regular slotted containers. These taping heads are incorporated into most standard 3M-Matic™ case sealers. The compact size and simplicity of the taping head also makes it suitable for mounting in box conveying systems other than 3M-Matic™ case sealers. This includes replacement of other types of taping, gluing or stapling heads in existing case sealing machines. The AccuGlide™ 3 Upper and Lower Taping Heads - 3 inch have been designed and tested for use with Scotch® pressure-sensitive film box sealing tape.

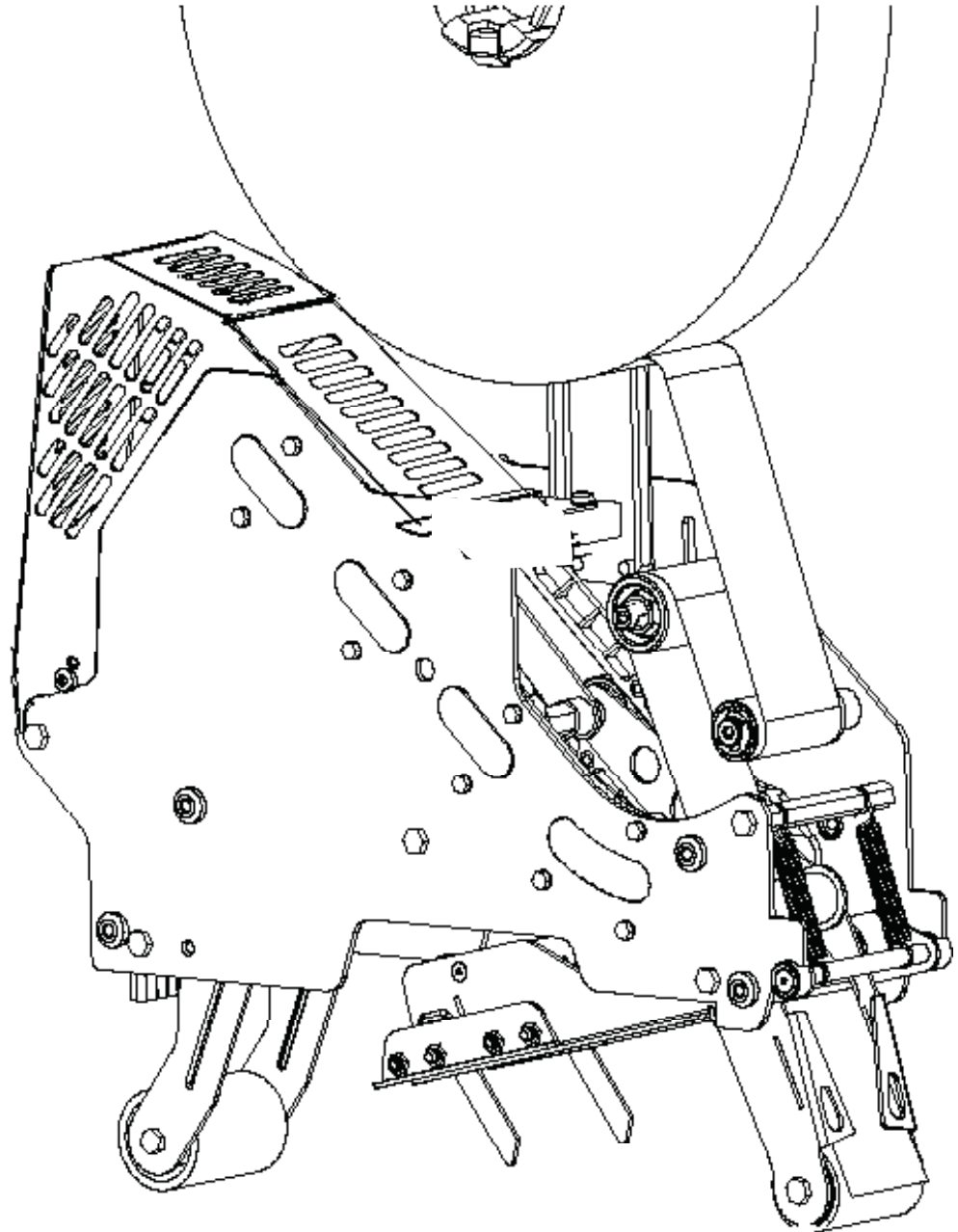

AccuGlide™ 3 Upper Taping Head - 3 inch, Type 10800

Taping Head Contents

AccuGlide™ 3 High Speed - 3 inch Upper and Lower Taping Heads consist of:

Qty.	Part Name
1	Taping Head Assembly
1	Tape Drum and Bracket Assembly
1	Hardware and Spare Parts Kit
1	Threading Tool

General Information

This instruction manual covers safety aspects, handling and transport, storage, unpacking, preparation, installation, operation, set-up and adjustments, technical and manufacturing specifications, maintenance, troubleshooting, repair work and servicing, electric diagrams, warranty information, disposal (ELV), a glossary with a definition of symbols, plus a parts list of the 3M-Matic™ Accuglide 3 (3 inch) 3M Industrial Adhesives and Tapes Division 3M Center, Bldg. 220-5E-06 St. Paul, MN 55144-1000 (USA) Edition April 2017/ Copyright 3M 2017. All rights reserved The manufacturer reserves the right to change the product at any time without notice.

How to use this Manual

The manual is an important part of the machine; all information contained herein is intended to enable the equipment to be maintained in perfect condition and operated safely. Ensure that the manual is available to all operators of this equipment and the manual is kept up to date with all subsequent amendments. Should the equipment be sold or disposed of, please ensure that the manual is passed on with the machine. Electrical and pneumatic diagrams are included in the manual. Equipment using PLC controls and/or electronic components will include relevant schematics or programs in the enclosure (or will be delivered separately as needed)

Keep the manual in a clean and dry place near the machine. Do not remove, tear or rewrite parts of the manual for any reason. Use the manual without damaging it. However, if the manual has been lost or damaged, ask your after sale service for a new copy (if it is possible, please have the manual name, part number, and revision information and/or model/machine name, machine type, and serial number) that are located on the identification plate (**For example: Model - Accuglide 3 - 3" - Type 10800 - Serial Number 13282**).

Note: All the important warning notes related to the operation of the machine are identified by the symbol:



Updating the Manual

Modifications to the machine are subject to manufacturer's internal procedures. The user may receive pages or parts of the manual which contain amendment made after its first publication. The user must use them to update this manual.

Important Safeguards

Explanation of Signal Word and Possible Consequences



This safety alert symbol identifies important messages in this manual. **READ AND UNDERSTAND THEM BEFORE INSTALLING OR OPERATING THIS EQUIPMENT.**



Caution

Indicates a potentially hazardous situation, which, if not avoided, may result in minor or moderate injury and/or property damage.



Warning

Indicates a potentially hazardous situation, which, if not avoided, could result in death or serious injury and/or property damage.



WARNING

- **To reduce the risk associated with mechanical hazards**
 - Read, understand and follow all safety and operating instructions before operating or servicing the case sealer
 - Allow only properly trained and qualified personnel to operate and or service this equipment



CAUTION

- **To reduce the risk associated with muscle strain:**
 - Use proper body mechanics when removing or installing taping heads that are moderately heavy or may be considered awkward to lift
- **To reduce the risk associated with impact hazards**
 - Place the taping head on a smooth level surface when maintaining or servicing this equipment



WARNING

- **To reduce the risk associated with shear, pinch, and entanglement hazards**
 - Turn air and electrical supplies off on associated equipment before performing any adjustments, maintenance, or servicing the taping heads
 - Never attempt to work on the taping head or load tape while the box drive system is running



WARNING

- **To reduce the risk associated with sharp blade hazards:**
 - Keep hands and fingers away from tape cutoff blades under orange blade guards. The blades are extremely sharp.

(Important Safeguards *continued* on next page)

Important Safeguards (continued)

Important - In the event the following safety labels are damaged or destroyed, they must be replaced to ensure operator safety. See "Replacement Parts Illustrations and Parts Lists" for label part numbers.

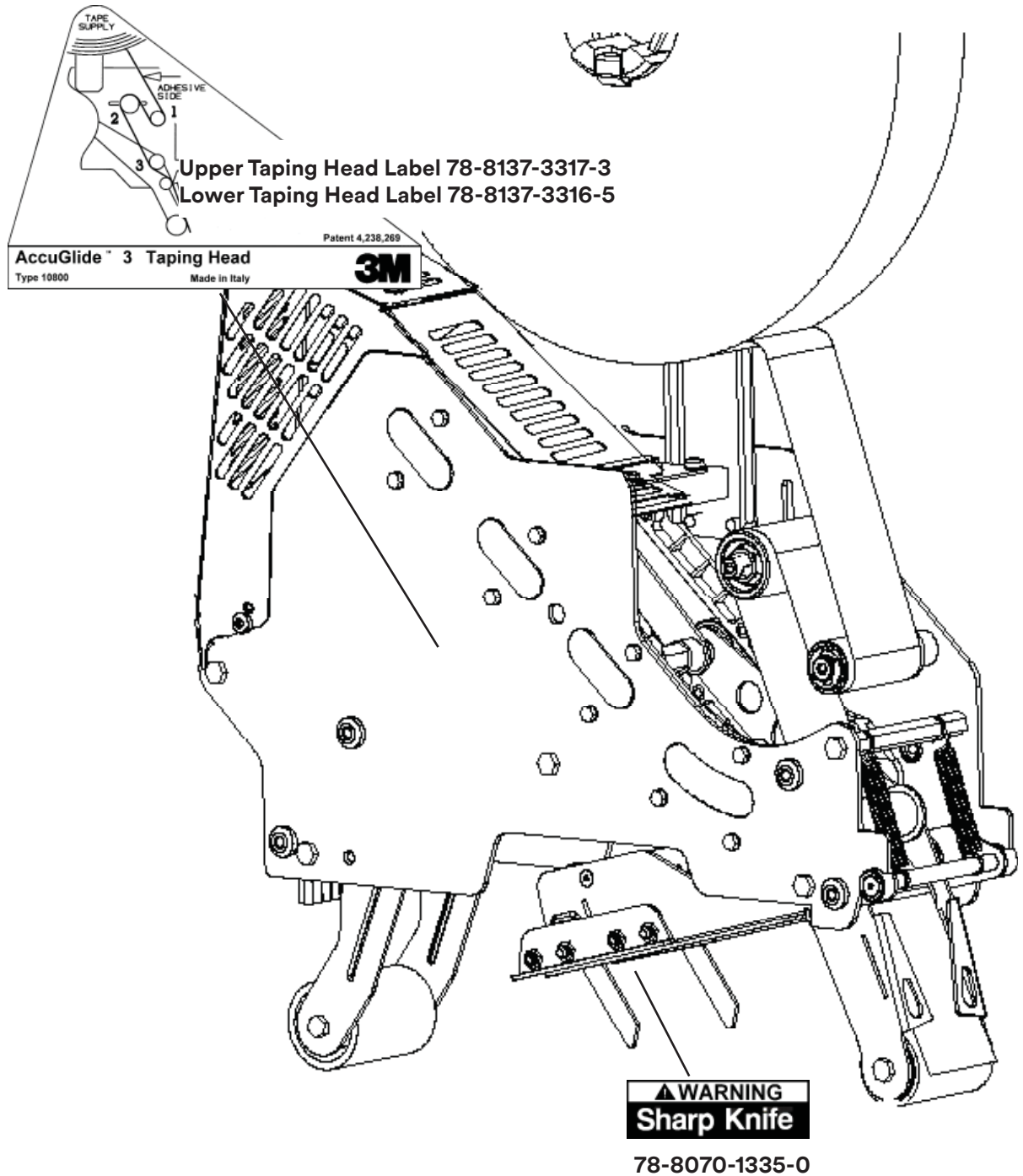

Figure 1-1 Replacement Labels/3M Part Numbers

Specifications

1. Tape:

For use with Scotch® pressure-sensitive film box sealing tapes.

2. Tape Width:

48mm [2 inches] minimum to 72mm [3 inches] maximum.

3. Tape Roll Diameter:

Up to 405mm [16 inches] maximum on a 76.2mm [3 inch] diameter core.
(Accommodates all system roll lengths of Scotch® film tapes.)

4. Tape Application Leg Length - Standard:

70mm ± 6mm [2-3/4 inches ± 1/4 inch]

Tape Application Leg Length - Optional:

50mm ± 6mm [2 inches ± 1/4 inch] (See “Adjustments – Tape Leg Length.”)

5. Box Size Capacities:

For use with center seam regular slotted containers.

<u>Minimum</u>	<u>Maximum</u>	
Length – 150mm [6 inches]	Unlimited	
Height – 120mm [4-3/4 inches] (most “3M-Matic” Case Sealers)] Limited by Case Sealer
90mm [3-1/2 inches] (with optional 2 inch leg length)		
Width – 150mm [6 inches]		

When upper and lower taping heads are used on “**3M-Matic**” case sealers, refer to the respective instruction manual specifications for box weight and size capacities.

6. Operating Rate:

Conveyor speeds up to 0.5 m/s [100 feet per minute].

7. Operating Conditions:

Use in dry, relatively clean environments at 5° to 40°C [40° to 105°F] with clean dry boxes.

Important – Taping heads should not be washed down or subjected to conditions causing moisture condensation on components.

8. Taping Head Dimensions:

Length – 443mm [17 3/8 inches]

Height – 648mm [25 1/2 inches] (with tape drum)

Width – 130mm [5-1/8 inches] (without mounting spacers)

Weight – Packaged: 8.2kg [18 lbs.] Unpackaged: 7.3kg [16 lbs.]

(Specifications *continued* on next page.)

Specifications *(continued)*

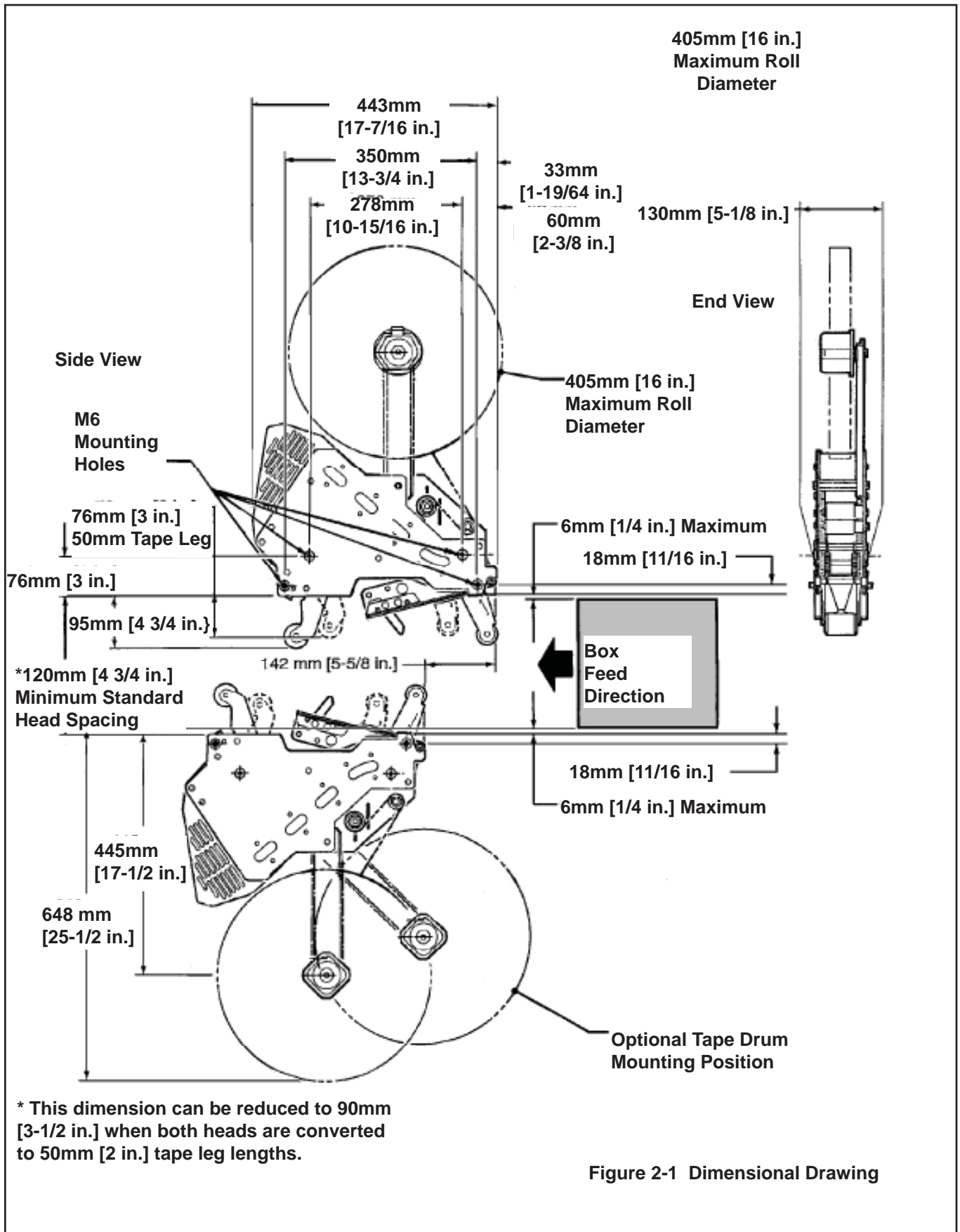

* This dimension can be reduced to 90mm [3-1/2 in.] when both heads are converted to 50mm [2 in.] tape leg lengths.

Figure 2-1 Dimensional Drawing

Installation



WARNING

- **To reduce the risk associated with sharp blade hazards:**
 - Keep hands and fingers away from tape cutoff blades under orange blade guards. The blades are extremely sharp.

Receiving And Handling

After the taping head assembly has been unpackaged, examine the unit for damage that might have occurred during transit. If damage is evident, file a damage claim immediately with the transportation company and also notify your 3M Representative.

Installation Guidelines

The taping head assembly can be used in converting existing or in custom made machinery.

It can be mounted for top taping or bottom taping. Refer to “Box Size Capacities,” as well as **Figure 2-1** in the Specifications section, for following points making installations:

Important – Always conduct a hazard review to determine appropriate guarding requirements when the installation is in an application other than 3M-Matic™ equipment

1. The box conveying system must positively propel the box in a continuous motion, not exceeding 0.50 m/s [100 feet per minute], past the taping head assembly since the box motion actuates the taping mechanism.



CAUTION

- **To reduce the risk associated with muscle strain:**
 - Use proper body mechanics when removing or installing taping heads that are moderately heavy or may be considered awkward to lift

2. If a pusher/cleated conveyor is used, steps should be taken in conveyor to prevent pusher from contacting applying or buffing roller arms (resulting in damage to taping head).
3. **Figure 2-1** illustrates the typical mounting relationship for opposing taping head assemblies to allow taping of box heights down to 90mm [3-1/2 inches]. To tape box heights down to 70mm [2-3/4 inches], the taping heads must be completely staggered so only one tape seal is being applied at one time.

Note – AccuGlide™ 3 High Speed Upper Taping Head is supplied with a buffing arm guard. Adjustments to guard may be required to install taping head into some older design case sealers.
4. Mounting studs are provided with the taping head, but special installations may require alternate mounting means.
5. Box hold-down/guide skis should be provided and taping head mounted so that side plates are 6mm [1/4 inch] maximum away from the ski surface on which the box rides.

Tape Leg Length

Taping heads are factory set to apply standard 70mm [2-3/4 inch] tape legs. The heads can be converted to apply 50mm [2 inch] tape legs if but both upper and lower heads must be set to apply the same tape leg length. See “Adjustments – Changing Tape Leg Length from 70 to 50mm [2-3/4 to 2 Inches].” Also, conveyor speed at which the product moves through taping heads affects the leading and trailing tape leg length. See “Adjustments section - Leading Tape Leg Length Adjustment.”

Tape Width Adjustment

Taping heads are factory set to apply 76mm [3 inch] wide tape. If it is necessary to align the tape or to apply narrower tapes, refer to “Adjustments – Tape Web Alignment” set-up procedure.

Operation

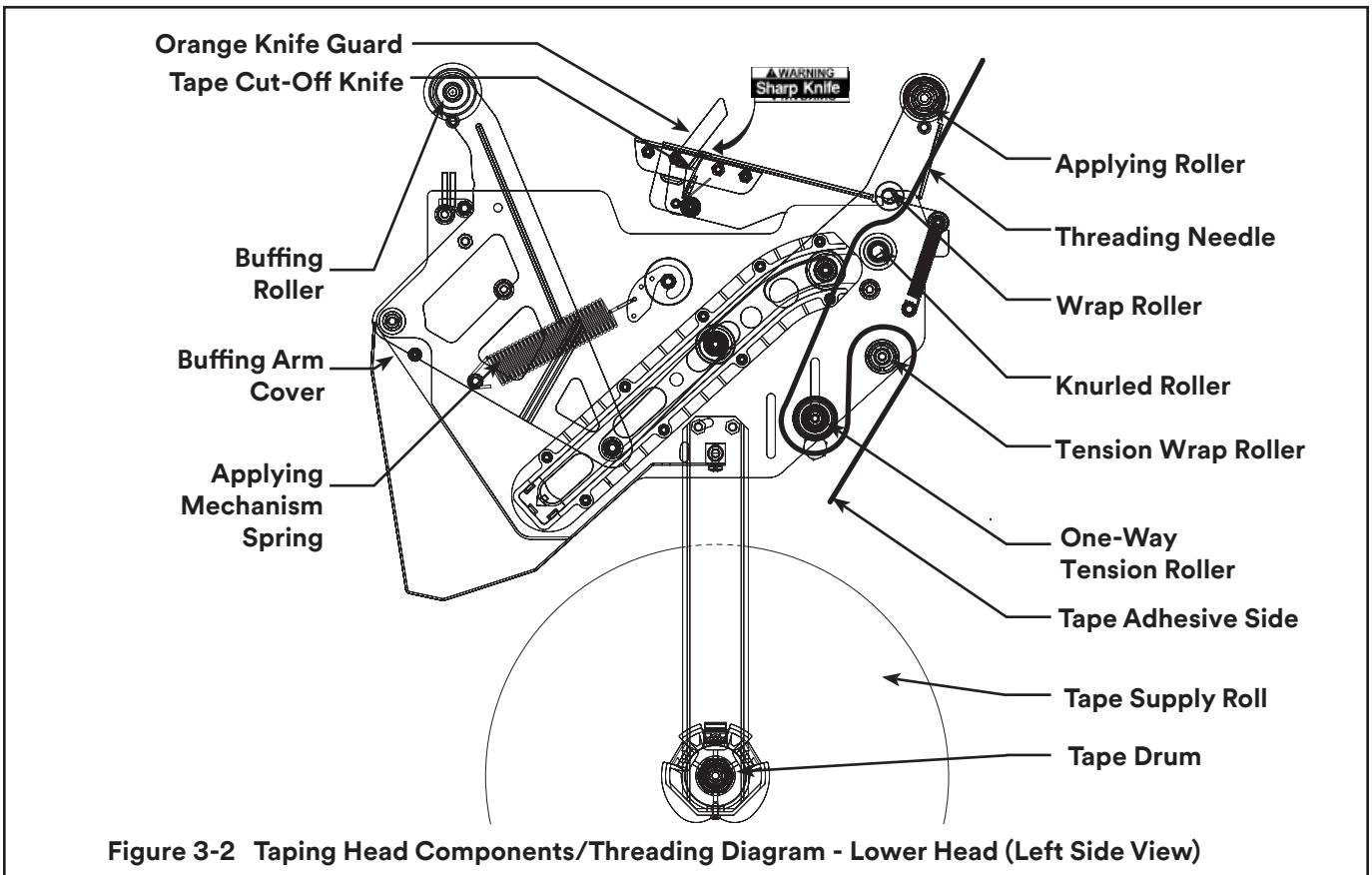
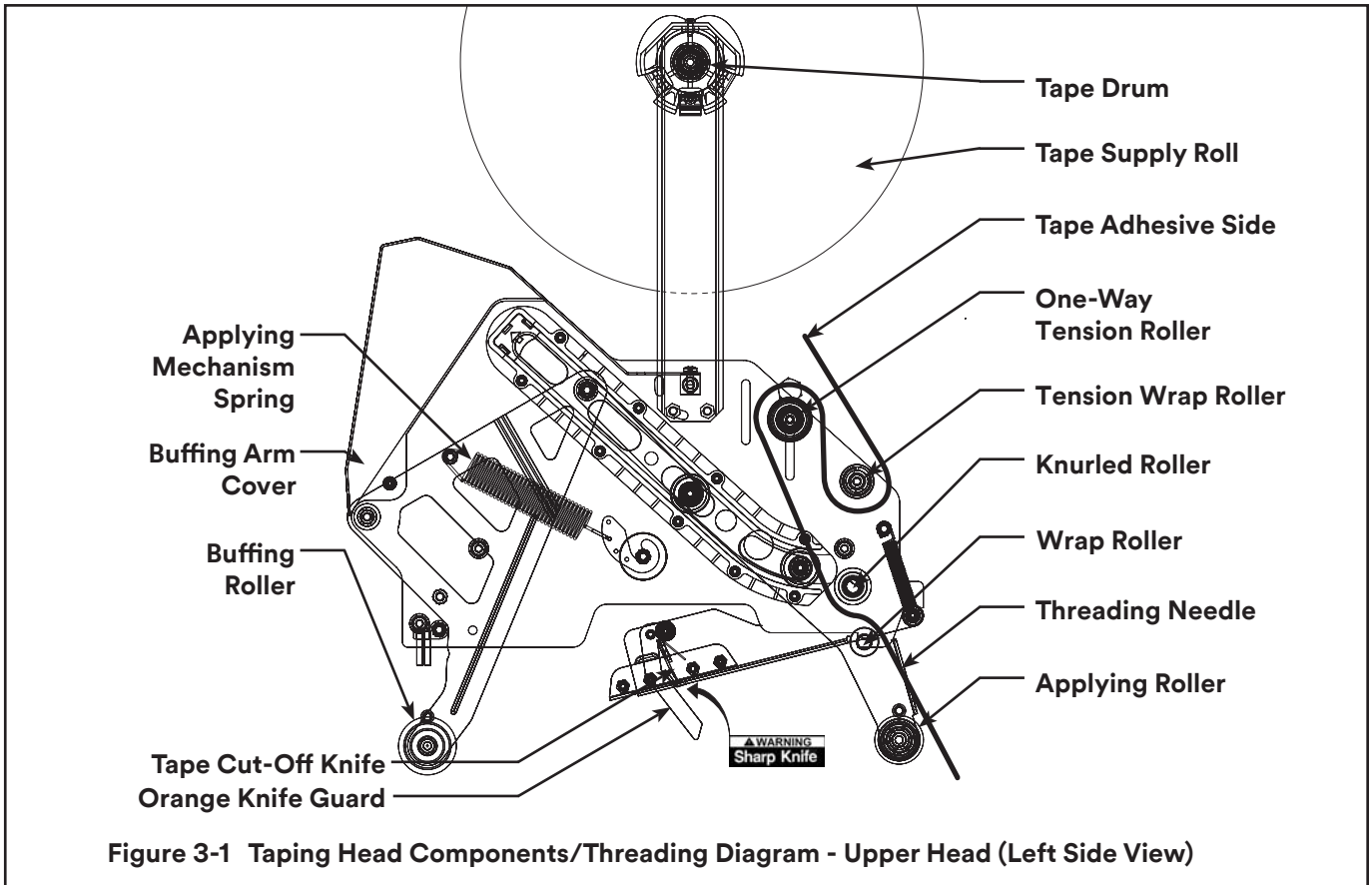



WARNING

- **To reduce the risk associated with sharp blade hazards:**
 - Keep hands and fingers away from tape cutoff blades under orange blade guards. The blades are extremely sharp.

It is recommended that the detailed instructions and sketches in this manual be referred to the first few times the taping head is loaded/threaded until the operator becomes thoroughly familiar with the tape loading operation.

Note – Remove tape roll before removing taping head from machine to minimize weight.

Tape Loading – Upper Taping Head

1. Place the upper taping head in a convenient working position.
2. Use **Figures 3-3/3-5** and tape threading label. Position tape roll so adhesive side of tape faces front of taping head as it's pulled from supply roll.
3. Attach the threading needle to the end of the roll. Guide the threading needle around the wrap roller (Position 1) then back around the one-way tension roller (Position 2).
4. Continue pulling the threading needle down and guide it between the two rollers on the apply arm (Position 3).
5. Pull threading needle down until tape travels between apply plate and ears of apply arm (Position 4) until extends past apply roller. When threaded adhesive side of tape should face knurled rollers at position 2 and also position 3.
6. Cut away any excess tape.

Important – Do not cut against apply roller - roller damage could occur.

Tape Loading – Lower Taping Head

1. Remove the lower taping head from the conveyor bed or associated equipment and place it a convenient working position.
2. Lower taping head is loaded and threaded in same manner as upper head.



WARNING

- **To reduce the risk associated with shear, pinch, and entanglement hazards**
 - Turn air and electrical supplies off on associated equipment before performing any adjustments, maintenance, or servicing the taping heads
 - Never attempt to work on the taping head or load tape while the box drive system is running



CAUTION

- **To reduce the risk associated with muscle strain:**
 - Use proper body mechanics when removing or installing taping heads that are moderately heavy or may be considered awkward to lift
- **To reduce the risk associated with impact hazards**
 - Place the taping head on a smooth level surface when maintaining or servicing this equipment

Figure 3-3

Insert threading needle through rollers in direction indicated by arrows.

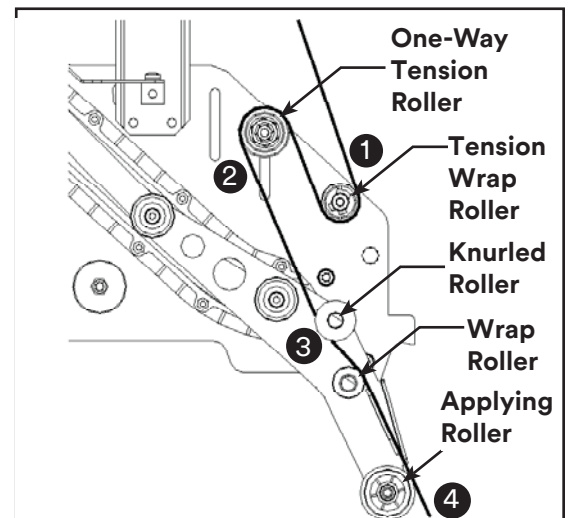

Figure 3-3 Tape Loading/Threading

Operation *(continued)*

Figure 3-4

Place tape roll on tape drum to dispense tape with adhesive side forward. Seat tape roll fully against back flange of drum. Adhere tape lead end to threading needle as shown.

Manually turn tape roll to create slack tape while pulling threading needle through tape applying mechanism until needle is through and tape is in alignment with applying roller.

Excess tape can be cut with a scissors at applying roller.



WARNING

- **To reduce the risk associated with sharp blade hazards:**
 - Keep hands and fingers away from tape cutoff blades under orange blade guards. The blades are extremely sharp.

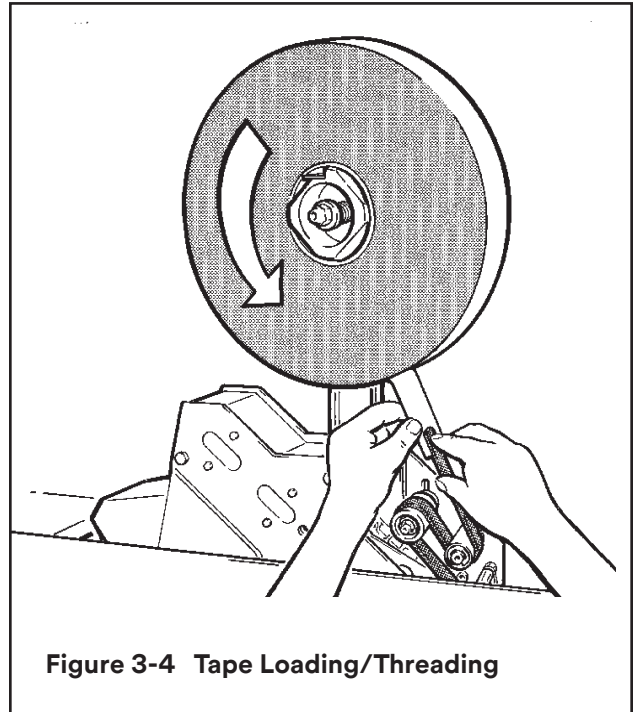

Figure 3-4 Tape Loading/Threading

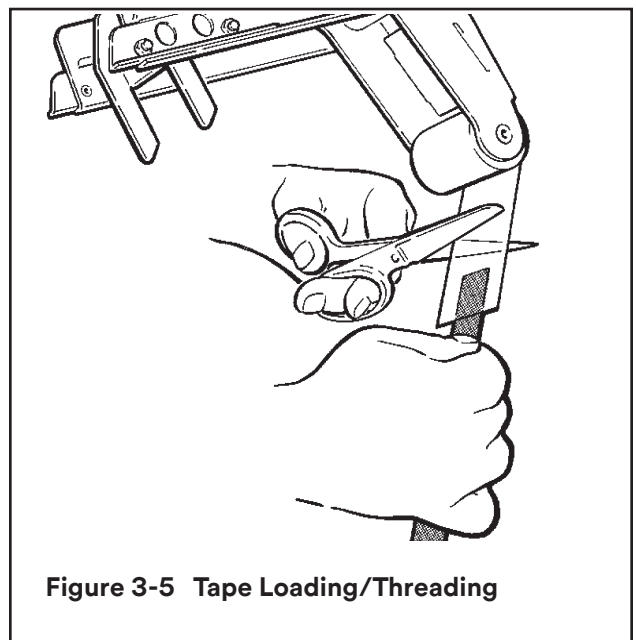

Figure 3-5 Tape Loading/Threading

Maintenance

The AccuGlide™ 3 High Speed 3 inch Taping Head has been designed for long, trouble free service. The taping head will perform best when it receives routine maintenance and cleaning. Taping head components that fail or wear excessively should be promptly repaired or replaced to prevent damage to other portions of the head or to the product.

Blade Replacement, Upper and Lower Taping Heads – Figure 4-1

1. Loosen, but do not remove, the blade screws (A). Remove and discard old blade.
2. Mount the new blade (B) with the beveled side away from the blade holder.
3. Bottom the blade slots against the screws (this will position the blade at the correct angle.) Tighten the blade screws to secure the blade.

Note – Check the blade position to insure proper clearance between blade and guard by slowly pivoting blade guard back.

Blade Guard

The blade guard covers the blade whenever a box is not being taped. Periodically check to be sure the blade guard is functioning properly and returning to cover the blade. Replace any defective parts.

Blade Oiler Pad

To reduce adhesive build-up, the taping heads are equipped with a factory pre-lubricated felt oiler pad that provides a film of oil on the cutting edge of the blade. Blade maintenance should include keeping the felt oiler pad saturated with Silicone.

Should tape adhesive build-up occur on blade, carefully wipe clean with an oily cloth.



WARNING

- To reduce the risk associated with shear, pinch, and entanglement hazards
 - Turn air and electrical supplies off on associated equipment before performing any adjustments, maintenance, or servicing the taping heads
 - Never attempt to work on the taping head or load tape while the box drive system is running

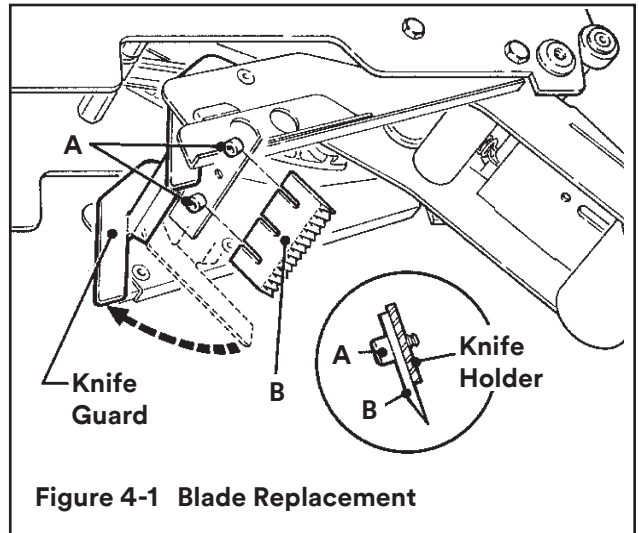

Figure 4-1 Blade Replacement



WARNING

- To reduce the risk associated with sharp blade hazards:
 - Keep hands and fingers away from tape cutoff blades under orange blade guards. The blades are extremely sharp.

(Maintenance *continued* on next page.)

Maintenance (continued)

Cleaning

Regular slotted containers produce a great deal of dust and paper chips when conveyed through taping heads. If this dust is allowed to build-up on the heads, it can cause wear on the moving parts. Excessive dirt build-up should be wiped off with a damp cloth. Cleaning should be done once per month, depending on the number and type of boxes used. If the boxes used are dirty, or if the environment in which the heads operate is dusty, cleaning on a more frequent basis may be necessary.

Note – Never attempt to remove dirt from taping heads by blowing it out with compressed air. This can cause the dirt to be blown inside components onto sliding surfaces. Dirt in these areas can cause serious equipment damage. Never wash down or subject taping heads to conditions causing moisture condensation on components. Serious equipment damage could result.

Applying/Buffering Roller Replacement

Replacing roller requires removal of shaft and mounting screws. With no area on the shaft to grip, the shaft often turns when attempting to remove the second screw. To ease removal of second screw, a 5mm hex socket has been provided at the bottom of the threads in both ends of the shaft. Insert a 4mm hex key wrench into this socket after removing one screw to hold the shaft for removal of the second screw. See **Figure 4-2**.

 **WARNING**

- **To reduce the risk associated with shear, pinch, and entanglement hazards**
 - Turn air and electrical supplies off on associated equipment before performing any adjustments, maintenance, or servicing the taping heads
 - Never attempt to work on the taping head or load tape while the box drive system is running

 **WARNING**

- **To reduce the risk associated with sharp blade hazards:**
 - Keep hands and fingers away from tape cutoff blades under orange blade guards. The blades are extremely sharp.

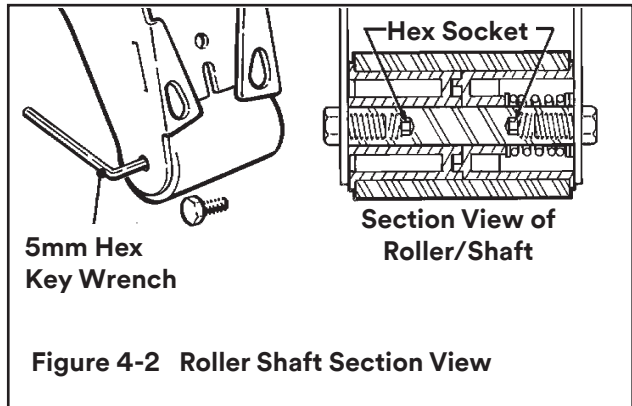

Adjustments

Tape Latch Alignment – Figure 5-1

The Latching tape drum assembly is pre-set to accommodate 76mm [3 inch] wide tape. Tape drum assembly is adjustable to provide alignment of narrower tapes.

To move the latch to a position that corresponds to a new tape core width (**Figure 5-1**):

1. Remove screw from the latch.
2. Move latch to position that corresponds to the tape core width.
3. Replace screw in new latch location.

To adjust or center tape width on centerline of taping head (and box center seam - **Figure 5-2**):

1. Loosen locking hex nut behind tape drum bracket on tape drum shaft. Use an adjustable wrench or 25mm open end wrench.
2. Using 5mm Hex Wrench, turn tape drum shaft in/out to center tape web.
3. Tighten locking hex nut to secure the adjustment.

No other components require adjustment for tape web alignment.

Tape Drum Friction Brake – Figure 5-3

The tape drum friction brake on taping head is pre-set for normal operation to prevent tape roll over travel. Should tension adjustment be required, turn self-locking nut on shaft to vary spring compression. Turn nut clockwise to increase braking force, and counterclockwise to decrease braking force.

Adjust brake to minimum tension to prevent tape roll over travel.

Note – Excess braking force will cause poor tape application and may lead to tape tabbing on trailing tape leg.

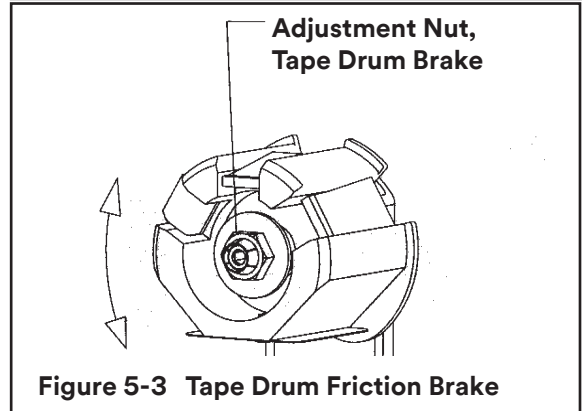
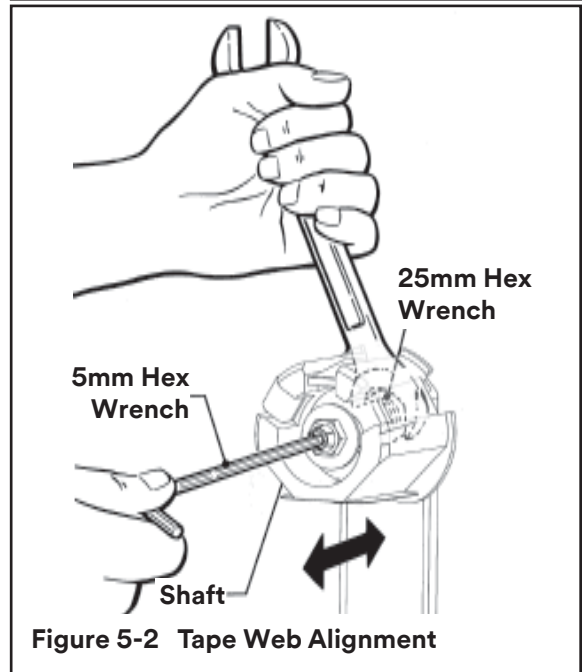
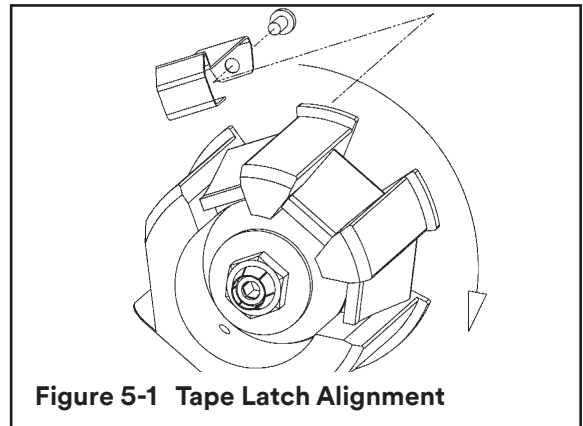

 WARNING
<ul style="list-style-type: none">• To reduce the risk associated with shear, pinch, and entanglement hazards<ul style="list-style-type: none">- Turn air and electrical supplies off on associated equipment before performing any adjustments, maintenance, or servicing the taping heads- Never attempt to work on the taping head or load tape while the box drive system is running

(adjustments *continued* on next page.)

Adjustments *(continued)*

Applying Mechanism Spring

To obtain access to spring, remove taping head cover (four mounting screws). Replace cover to finish.

The applying mechanism spring, shown in **Figures 5-4A and 5-4B**, controls applying/buffing roller pressure on box and returns the mechanism to reset position. The spring pressure is pre-set, as shown in **Figure 5-4A** for normal operation, but is adjustable. If a tape gap appears on trailing surface of box increase spring pressure. If front of box is being crushed by applying roller decrease spring pressure. Removing spring end loop from spring holder and placing loop in other holes provided to adjust spring pressure (see **Figure 5-4B**).

One-Way Tension Roller

Figure 5-5

The one-way tension roller is factory set. When replacing this assembly, the roller must have 0,5 kg [1 lb.] min. tangential force when turning.

To Adjust Tension:

1. Wrap a cord or small strap (non-adhesive) 4-6 turns around the tension roller.
2. Attach a spring scale to the end of the cord or strap.
3. Turn adjusting nut (with socket wrench provided) until required force of approximately 0.5 kg to 0.9 kg [1 to 2 lbs.] is reached to turn roller pulling on spring scale.



WARNING

- To reduce the risk associated with shear, pinch, and entanglement hazards
 - Turn air and electrical supplies off on associated equipment before performing any adjustments, maintenance, or servicing the taping heads
 - Never attempt to work on the taping head or load tape while the box drive system is running

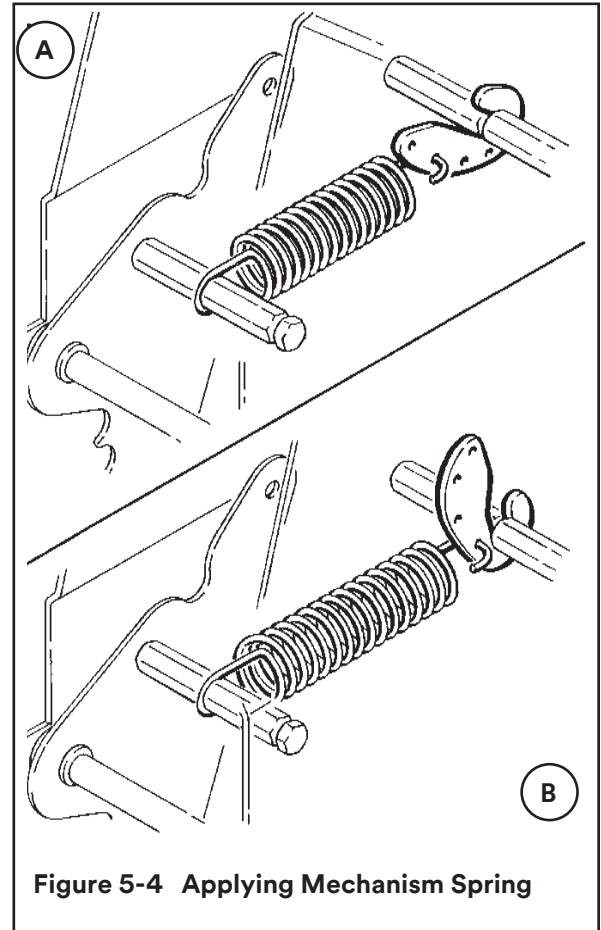

Figure 5-4 Applying Mechanism Spring

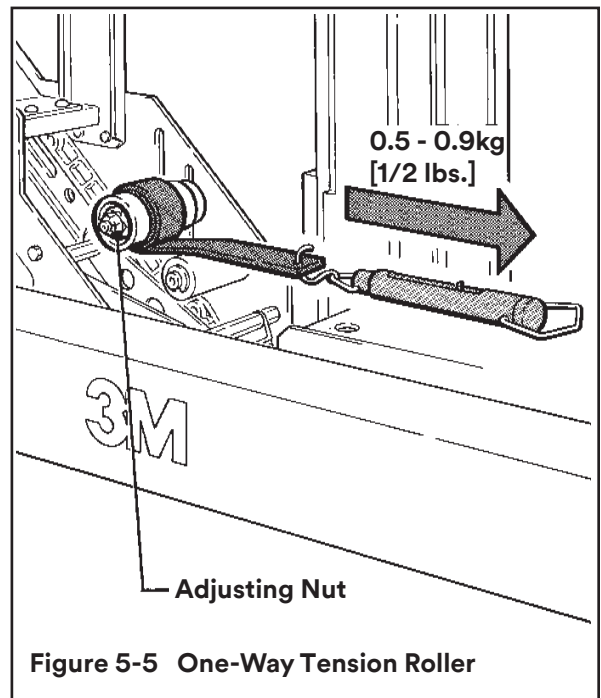

Figure 5-5 One-Way Tension Roller

(Adjustments *continued* on next page.)

Adjustments *(continued)*

Tape Leg Length

Leading Tape Leg Length Adjustment – Figure 5-6

The one-way tension roller position is adjustable to control the leading tape leg length.

Moving this roller farther away from the box top or bottom surface will decrease the leading leg length.

Moving it closer to the box top or bottom surface will increase the leading leg length.

Changing Tape Leg Length from 70 to 50mm [2 3/4-2 Inches] – Figure 5-7

Note – When changing tape leg length, both upper and lower heads must be adjusted to apply same leg lengths.

1. Remove and retain two hex head screws and remove the brush from normal position “A” on side frame.
2. Remount and secure brush in position “A-A” on side frame forward of normal location with original fasteners.
3. Remove cut-off bracket extensions from position “B”.
4. Remount cut-off bracket extensions in forward position “B-B”.
5. Remove/retain one-way tension roller assembly from slot “C” in frame.
6. Remount tension roller assembly near top of slot “C-C” in frame using original fasteners.
7. Adjust tension roller according to “Leading Tape Leg Length Adjustment” above.

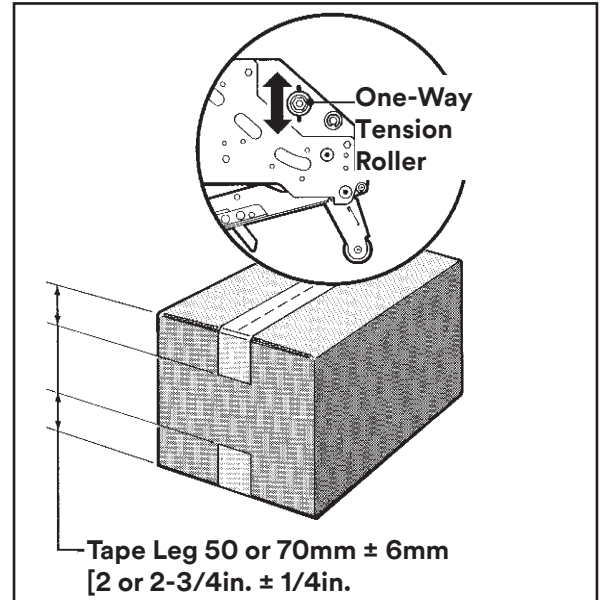

Figure 5-6 Leading Tape Leg Length

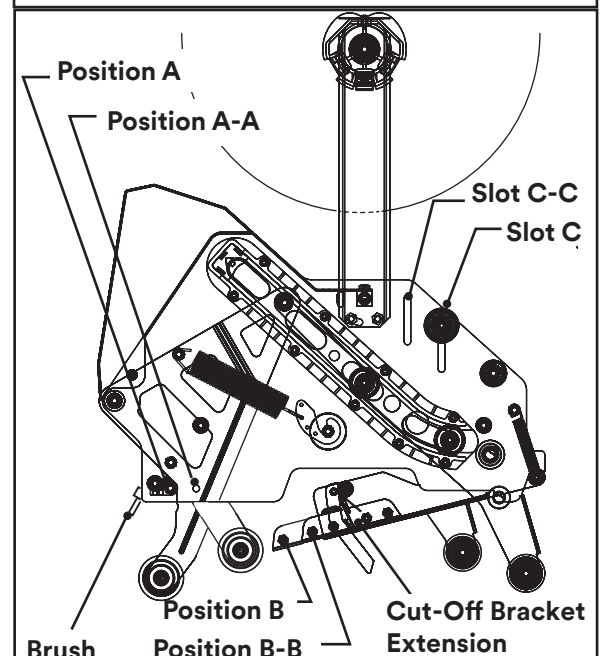

Figure 5-7 Changing Tape Leg Length



WARNING

- To reduce the risk associated with shear, pinch, and entanglement hazards
 - Turn air and electrical supplies off on associated equipment before performing any adjustments, maintenance, or servicing the taping heads
 - Never attempt to work on the taping head or load tape while the box drive system is running



WARNING

- To reduce the risk associated with sharp blade hazards:
 - Keep hands and fingers away from tape cutoff blades under orange blade guards. The blades are extremely sharp.

Troubleshooting

Troubleshooting Guide

Problem	Cause	Correction
The tape leg on the front of the case is too long	The tape is threaded incorrectly	The tape must go around the wrap roller before going around the one-way tension roller
	The tape tension is too low	Adjust the one-way tension roller
	The knurled roller drags	Check for adhesive build-up between the knurled roller and its shaft. Clean and lubricate shaft. Remove all lubricant from roller surfaces.
	Tape tracks to one side or drags on the support tabs of applying frame	Adjust the tape web alignments
	The one-way tension roller is not correctly positioned	Position the roller in its mounting slot so that the tape extends just beyond the centerline of the applying roller
	Taping head is not set up properly	Check leg length adjustments
The blade does not cut tape or the tape end is jagged/shredded	The blade is dull and/or has broken teeth	Replace the blade
	Tape tension is insufficient	Increase tape tension by adjusting the one-way tension roller
	Adhesive has built up on the blade	Clean and adjust the blade
	The blade not positioned properly	Make sure the blade is bottomed out against the mounting bolts
	The blade is dry	Lubricate the blade oiler pad on the blade guard
	The blade is in backwards	Mount the blade so that the beveled edge is away from the entrance of the head
	One or both cutter springs are missing or stretched	Replace the defective spring(s)
	Tension roller surface is not fully contacting the taping head frame	Make sure one-way bearing is below the surface of the tension roller. If not, press bearing further into roller or replace roller.

Troubleshooting *(continued)*

Troubleshooting Guide

Problem	Cause	Correction
Tape is tabbing on the trailing leg on the back of the box	There is excess tension on the tape drum assembly and/or the one-way tension roller assembly	Adjust the one-way tension roller and/or the tape drum assembly
	Rollers in the tape path do not rotate freely	Clean adhesive deposits from the surface, ends, and shafts of the rollers. Then lubricate roller shafts. Remove all lubricant from roller surfaces.
	The blade is not cutting tape properly	Refer to tape cutting problems
	The tape is threaded incorrectly	Re-thread the tape
The tape end does not stay in application position in front of the applying roller	Applying mechanism spring has too little tension	Move spring hook to next tighter hole
	The tape is incorrectly threaded	Re-thread the tape
	Flanged knurled roller overruns on return of applying mechanism to its rest position	Adjust tension roller position in mounting slot to lengthen tape leg
	Applying roller overruns on return of applying mechanism to its rest position	There should be a slight drag when rotating the applying roller. If not, check friction springs and/or friction pins and replace if necessary
Tape not centered on box seam	The one-way tension roller is not correctly positioned	Position roller in its mounting slot so that tape end extends beyond centerline of applying roller
	The one-way tension roller is defective	Replace the one-way tension roller
Tape not centered on box seam	Tape drum not centered	Reposition tape drum
	Centering guides not centered	Adjust centering guides
	Box flaps not of equal length	Check box specifications

Spare Parts/Service Information

Recommended Spare Parts

Listed are a set of spare parts that will periodically require replacement due to normal wear. These parts should be ordered to keep the taping heads in production:

AccuGlide™ 3 Upper Taping Head - 3 inch

Qty.	Part Number	Description
4	78-8076-4500-3	Stud – Mounting
1	78-8137-3311-6	Spring – Upper Extension
1	78-8028-7899-7	Blade – 89mm/3.5 Inch
2	78-8052-6602-6	Spring – Cutter
1	78-8076-4726-4	Tool – Tape Threading

AccuGlide™ 3 Lower Taping Head - 3 inch

Qty.	Part Number	Description
1	78-8028-7899-7	Blade – 89mm/3.5 Inch
2	78-8052-6602-6	Spring – Cutter
4	78-8076-4500-3	Stud – Mounting
1	78-8137-3312-4	Spring – Lower Extension
1	78-8076-4726-4	Tool – Tape Threading

In addition to the above set of spare parts supplied with the taping head, it is suggested that the following spare parts be maintained which will require replacement under normal wear of the taping head.

Qty.	Part Number	Description
1	78-8057-6181-0	Roller – Applying
1	78-8057-6180-2	Roller – Buffing
1	78-8113-7030-9	Spring – Torsion

Replacement Parts and Service

Refer to the first page of this instruction manual “**Replacement Parts and Service Information**”.

Spare Parts/Service Information *(continued)*

Replacement Parts Illustrations and Parts Lists

AccuGlide™ 3 High Speed 3 inch Upper Taping Head, Type 10800

AccuGlide™ 3 High Speed 3 inch Lower Taping Head, Type 10800

1. Refer to the Taping Head Assemblies Figure to find all the parts illustrations identified by figure numbers.
2. Refer to the figure or figures to determine the individual parts required and the parts reference number.
3. The replacement parts list, that follows each illustration, includes the part number and part description for the parts in that illustration.

Note – The complete description has been included for standard fasteners and some commercially available components. This has been done to allow obtaining these standard parts locally, should the customer elect to do so.

4. Refer to the first page of this instruction manual "Replacement Parts and Service Information" for replacement parts ordering information.

Important – Not all the parts listed are normally stocked items. Some parts or assemblies shown are available only on a special order basis. Contact 3M/Tape Dispenser Parts to confirm item availability.

Tape Head -
AccuGlide™ 3 - 3 inch

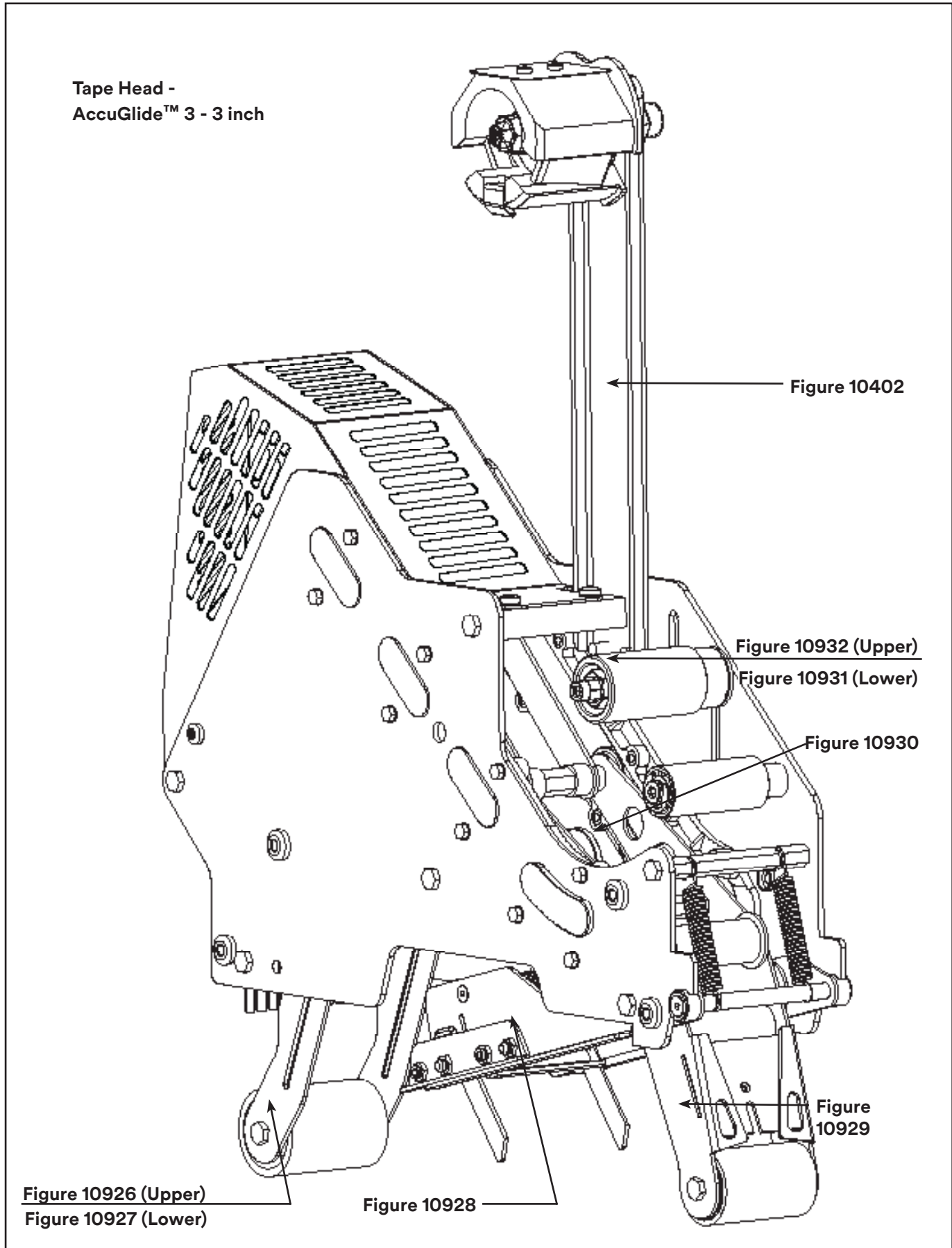

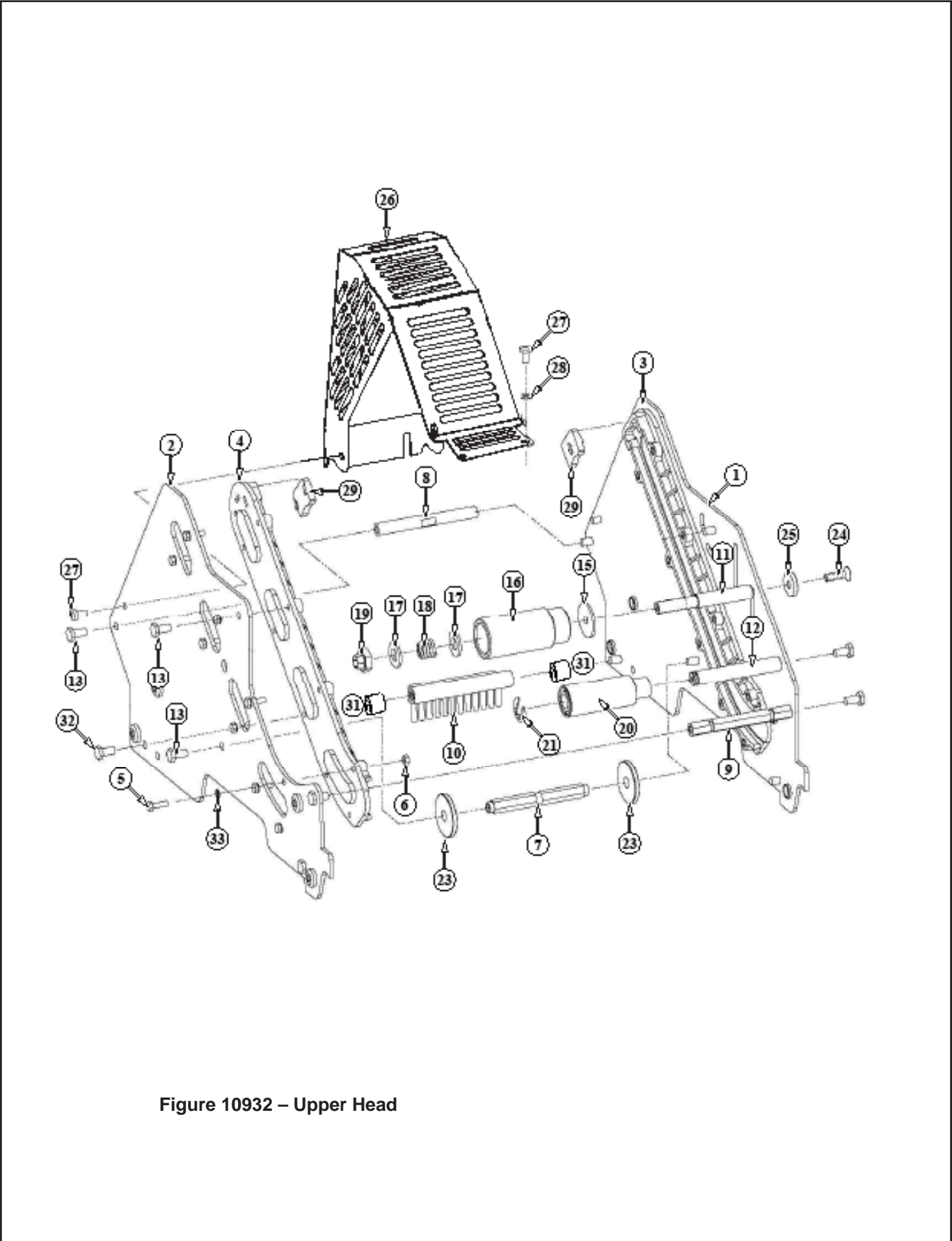

Figure 10932 – Upper Head

Figure 10932 – Upper Head

Ref. No.	3M Part No.	Description
10932-1	78-8137-3294-4	Frame – Tape Mount Upper Assembly
10932-2	78-8137-3295-1	Frame – Front Upper Assembly
10932-3	78-8068-4143-9	Guide – #1
10932-4	78-8068-4144-7	Guide – #2
10932-5	78-8060-7818-0	Screw – Hex Hd, M4 x 12
10932-6	78-8010-7416-8	Nut – Hex Jam, M4
10932-7	78-8076-4735-5	Spacer – Spring
10932-8	78-8137-3309-0	Shaft - Pivot 115mm
10932-9	78-8060-7939-4	Spacer – 10 x 115 W/Slots
10932-10	78-8060-7936-0	Brush Assembly
10932-11	78-8054-8796-0	Shaft – Tension Roller
10932-12	78-8054-8798-6	Shaft – Wrap Roller
10932-13	26-1003-5829-5	Screw – Hex Hd, M6 x 12
10932-15	78-8100-1009-6	Washer – Special
10932-16	78-8054-8797-8	Roller – Top Tension
10932-17	26-1004-5510-9	Washer – Plain, M10
10932-18	78-8052-6567-1	Spring – Compression
10932-19	78-8017-9077-1	Nut – Self Locking, M10 x 1
10932-20	78-8054-8799-4	Roller – Wrap
10932-21	26-1000-1613-3	Ring – Retaining, Tru-Arc #1-420-0120-100
10932-22	78-8076-4500-3	Stud – Mounting (not shown)
10932-23	78-8076-5242-1	Stop – Cut-Off Frame
10932-24	78-8060-8179-6	Screw - Flat Head Hex, M6 x 20
10932-25	78-8076-5477-3	Washer – Special, 6.5 x 20 x 4
10932-26	78-8137-3310-8	Guard – Head
10932-27	78-8060-8087-1	Screw – M5 x 10
10932-28	78-8005-5741-1	Washer – Flat, M5
10932-29	78-8133-9615-3	Bumper
10932-30	78-8133-9605-4	Label – Threading, English Language
10932-31	78-8060-7937-8	Spacer 6.5 / 14 x 12.5
10932-32	78-8060-7938-6	Screw - Low Profile M6 x 25
10924-33	78-8076-4716-5	Star Washer 4mm

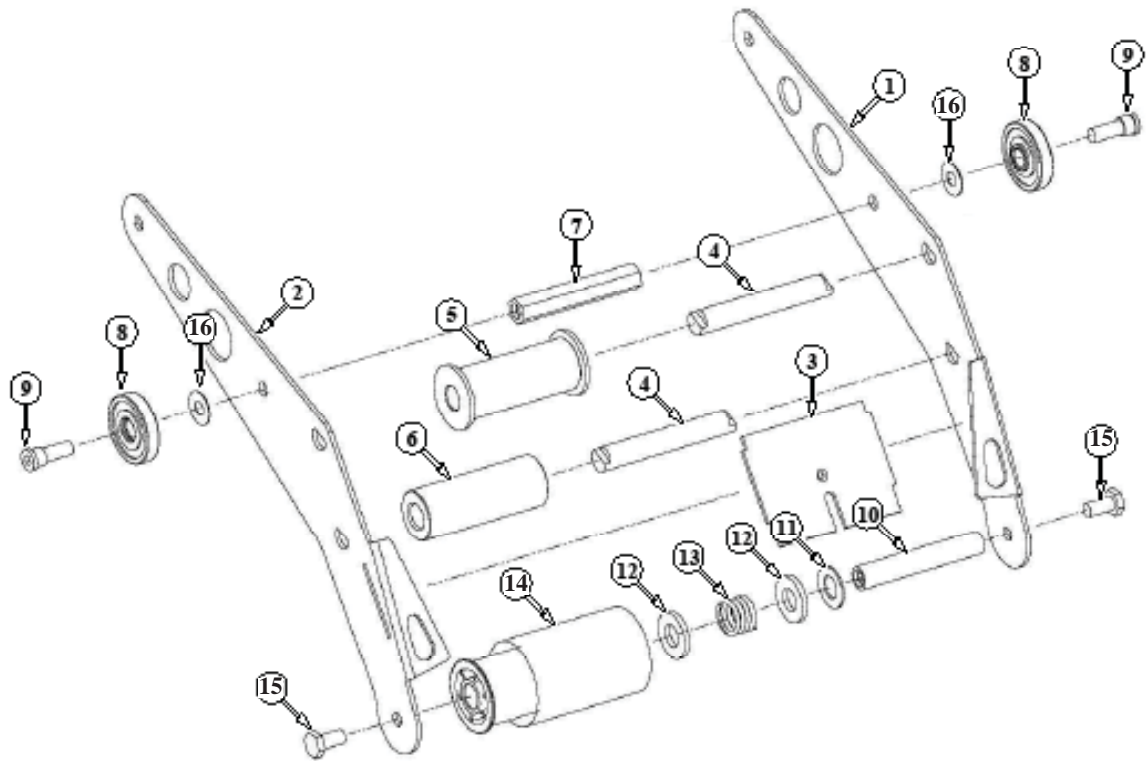

Figure 10929 – Upper and Lower Heads

Figure 10929 – Upper and Lower Heads

Ref. No.	3M Part No.	Description
10929-1	78-8133-9520-5	Arm – Applying, R/H
10929-2	78-8133-9521-3	Arm – Applying, L/H
10929-3	78-8070-1292-3	Plate – Back-Up
10929-4	78-8076-4736-3	Shaft Roller
10929-5	78-8076-4737-1	Roller Assembly – Knurled
10929-6	78-8076-4738-9	Roller – Wrap
10929-7	78-8054-8806-7	Spacer
10929-8	78-8017-9082-1	Bearing – Special, 30 mm
10929-9	78-8017-9106-8	Screw – Bearing Shoulder
10929-10	78-8054-8801-8	Shaft – 10 x 85, W/Hexagon
10929-11	78-8017-9074-8	Washer – Nylon, 15mm
10929-12	26-1004-5510-9	Washer – Friction
10929-13	78-8052-6567-1	Spring – Compression
10929-14	78-8137-1392-8	Assembly– Applying Roller
10929-15	26-1003-5829-5	Screw – Hex Hd, M6 x 12
10929-16	78-8094-6151-6	Washer - Flat, 6.5 ID x 15 OD x 0.5 Thk

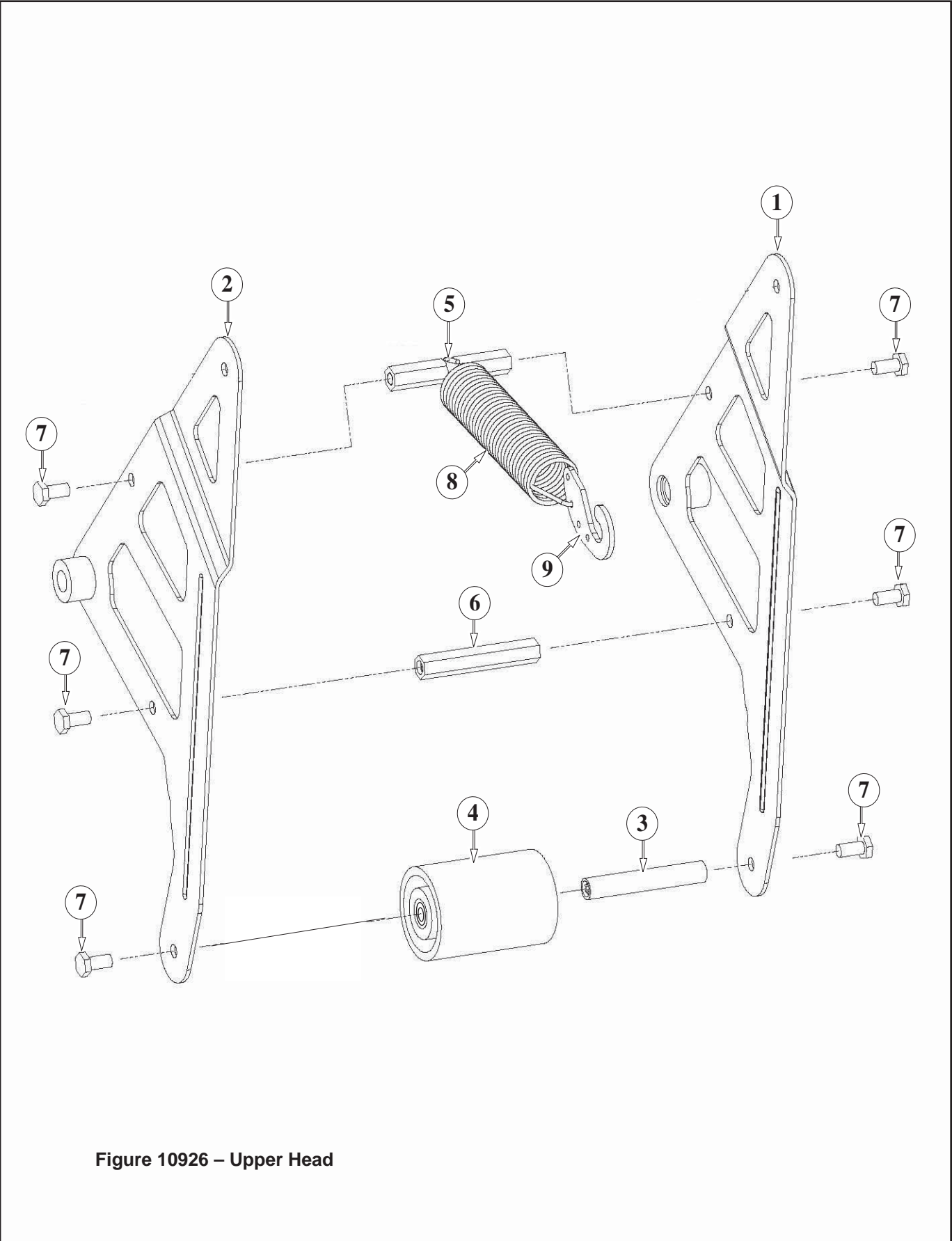

Figure 10926 – Upper Head

Figure 10926 – Upper Head

Ref. No.	3M Part No.	Description
10926-1	78-8137-3300-9	Buffing Arm – Sub Assembly
10926-2	78-8137-3301-7	Buffing Arm – Sub Assembly
10926-3	78-8091-0799-4	Shaft – 10 x 85, W/Hexagon
10926-4	78-8137-1397-7	Roller – Buffing Assembly
10926-5	78-8076-4739-7	Spacer – Spring
10926-6	78-8052-6580-4	Spacer
10926-7	26-1003-5829-5	Screw – Hex Hd, M6 x 12
10926-8	78-8137-3311-6	Spring – Upper (100 fpm)
10926-9	78-8070-1244-4	Holder – Spring

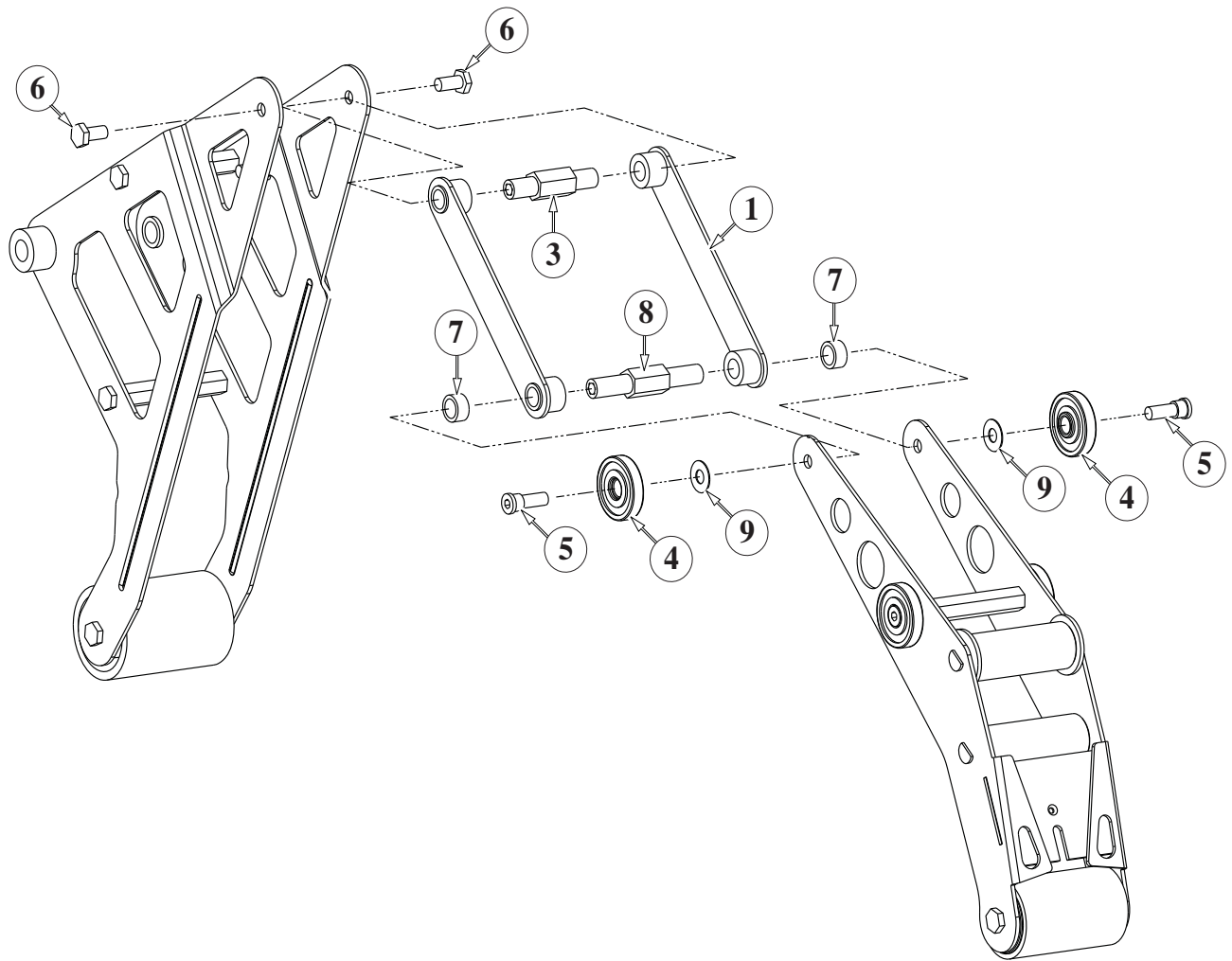

Figure 10930 – Upper and Lower Heads

Figure 10930 – Upper and Lower Heads

Ref. No.	3M Part No.	Description
10930-1	78-8137-3302-5	Link – R/H Assembly
10930-3	78-8137-3314-0	Shaft – Pivot, Buffing
10930-4	78-8017-9082-1	Bearing – Special 30 mm
10930-5	78-8017-9106-8	Screw – Bearing Shoulder
10930-6	26-1003-5829-5	Screw – Hex Hd, M6 x 12
10930-7	78-8137-3305-8	Spacer – Applying Pivot
10930-8	78-8137-3313-2	Shaft – Pivot, Applying
10930-9	78-8094-6151-6	Washer - Flat, 6.5 ID x 15 OD x 0.5 Thk

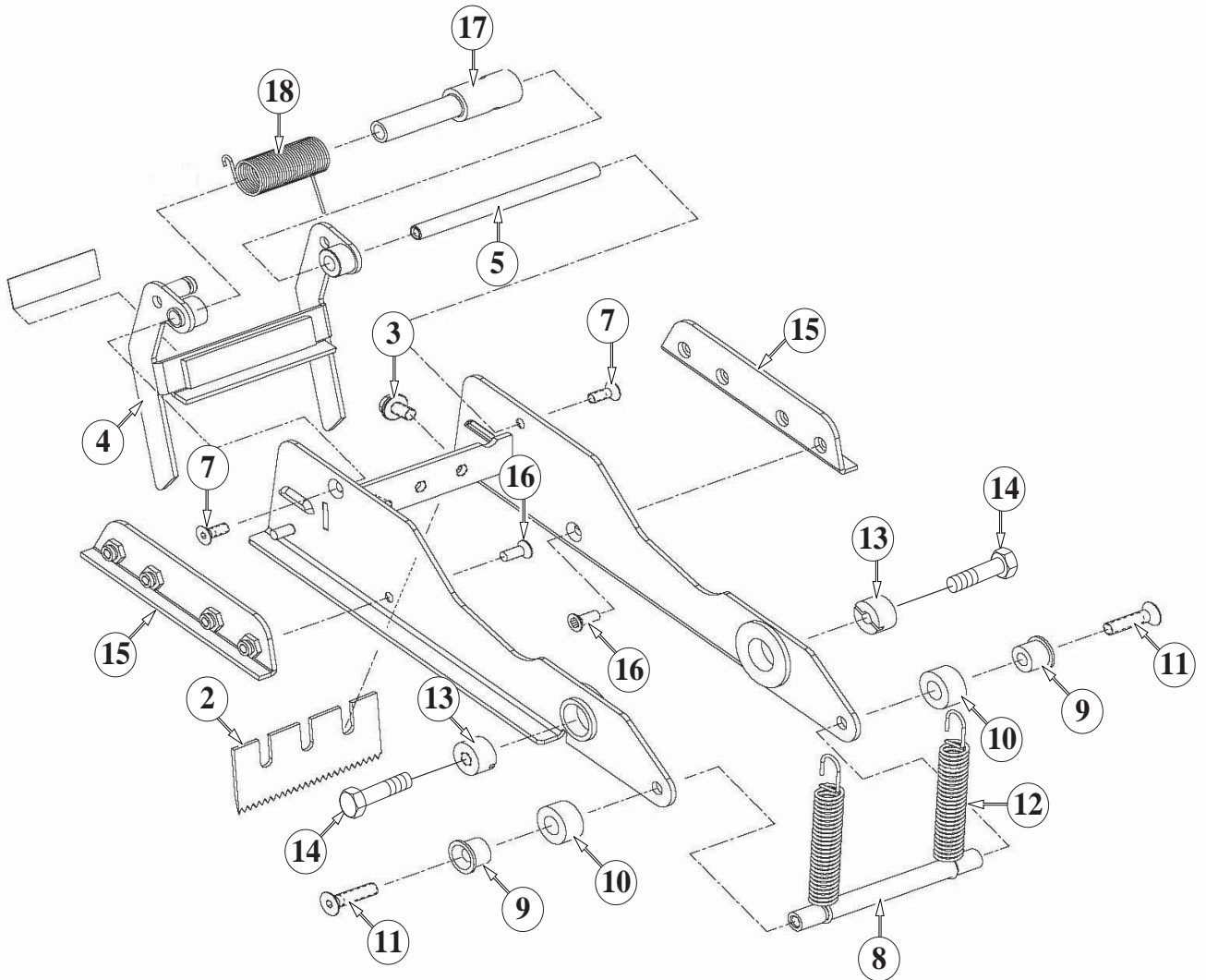

Figure 10928 – Upper and Lower Heads

Figure 10928 – 3" Upper and Lower Heads

Ref. No.	3M Part No.	Description
10928-1	78-8070-1283-2	Frame – Cut-Off
10928-2	78-8028-7899-7	Knife – 89 mm/3.5 Inch
10928-3	26-1002-5817-2	Screw – Hex Hd, M5 x 8
10928-4	78-8076-4741-3	Knife Guard Assembly – W/English Language Label
10928-5	78-8054-8813-3	Shaft – Knife Guard
10928-7	26-1005-4758-2	Screw – Flat Hd, Soc Dr, M4 x 10
10928-8	78-8060-7941-0	Pin – Spring Holder W/Slots
10928-9	78-8052-6600-0	Spacer
10928-10	78-8070-1269-1	Bumper
10928-11	26-1005-4757-4	Screw – Flat Hd, Soc Dr, M5 x 20
10928-12	78-8052-6602-6	Spring – Cutter
10928-13	78-8017-9132-4	Pivot – Cutter Lever
10928-14	26-1003-5828-7	Screw – Spec, Hex Hd, M6 x 10
10928-15	78-8070-1216-2	Slide – Extension
10928-16	26-1008-6574-5	Screw – Flat Hd, Phil Dr, M4 x 10
10928-17	78-8113-7060-6	Bushing – 83.7 mm Long
10928-18	78-8113-7030-9	Spring – Torsion
10928-19	78-8070-1335-0	Label – Warning, English

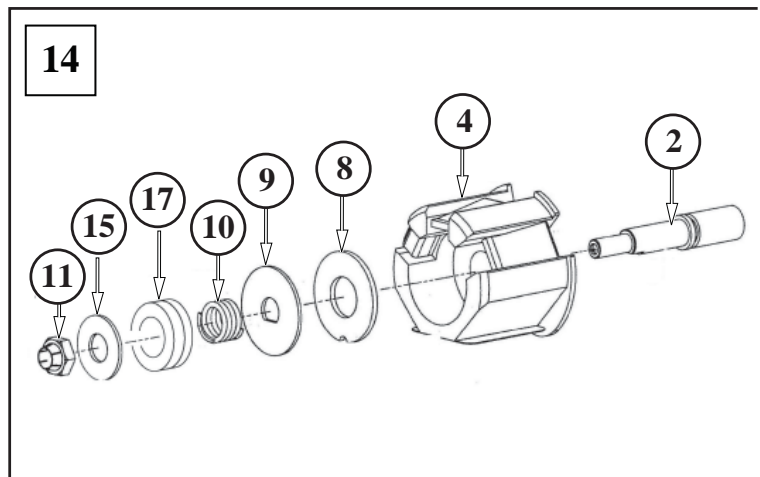
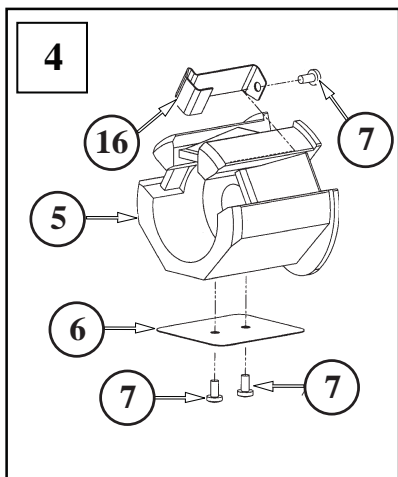
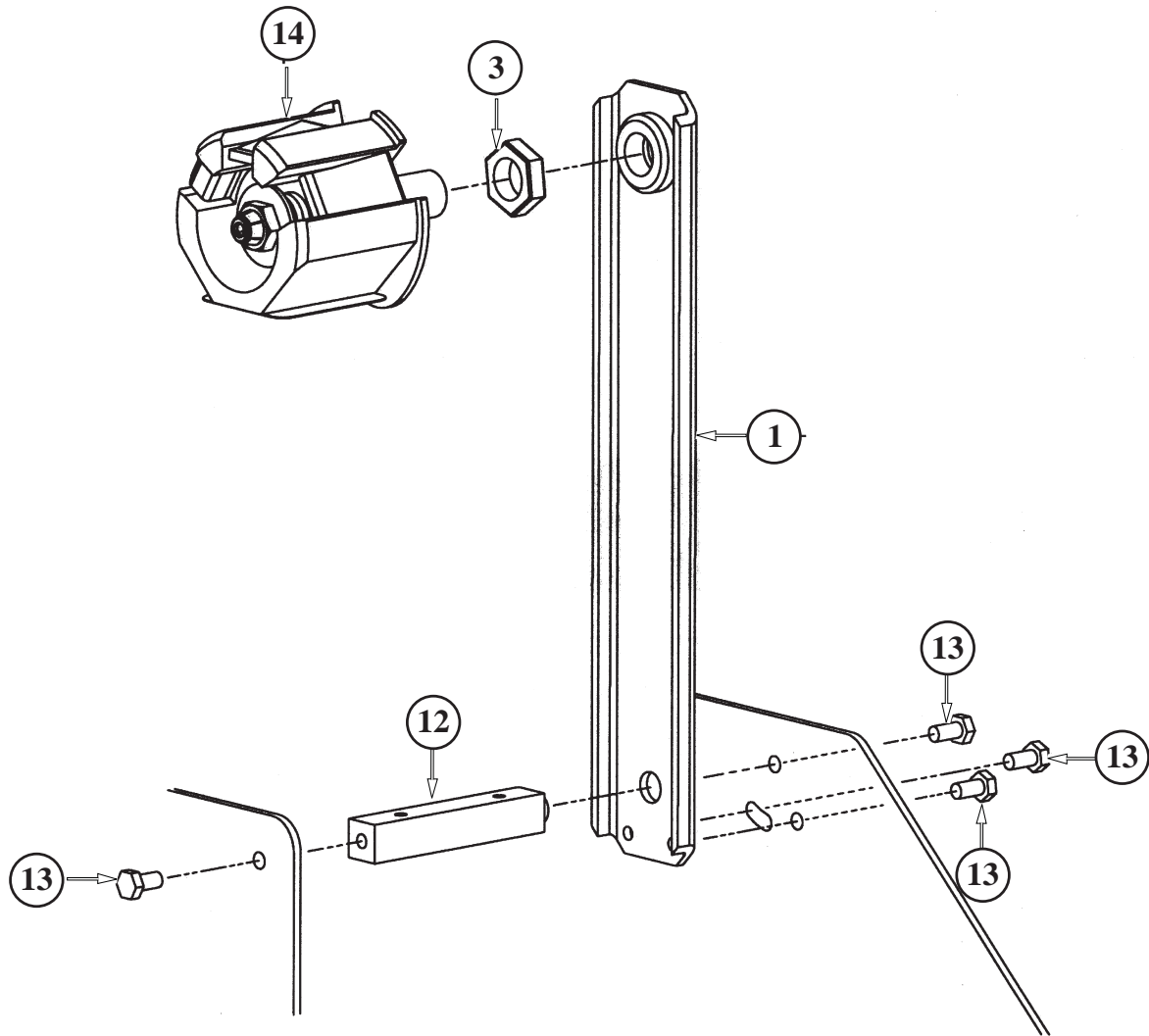

Figure 10402 – Upper and Lower Heads

Figure 10402 – 3” Latch Upper and Lower Heads

Ref. No.	3M Part No.	Description
10402-1	78-8070-1395-4	Bracket – Bushing Assembly
10402-2	78-8060-8462-6	Shaft – Tape Drum, 3 Inch Head
10402-3	78-8017-9169-6	Nut – M18 x 1
10402-4	78-8098-8829-6	Tape Drum Sub Assembly – 3 Inch Wide
10402-5	78-8098-8828-8	Tape Drum
10402-6	78-8098-8830-4	Leaf Spring
10402-7	26-1002-5753-9	Screw – Self Tapping
10402-8	78-8060-8172-1	Washer – Friction
10402-9	78-8052-6271-0	Washer – Tape Drum
10402-10	78-8100-1048-4	Spring – Core Holder
10402-11	78-8017-9077-1	Nut – Self Locking, M10 x 1
10402-12	78-8100-1050-0	Spacer – Bracket
10402-13	26-1003-5829-5	Screw – Hex Hd, M6 x 12
10402-14	78-8133-9641-9	Tape Drum Assembly – 3 Inch Head
10402-15	26-1004-5510-9	Washer – Plain, M10
10402-16	78-8098-8816-3	Latch – Tape Drum
10402-17	78-8052-6651-3	Washer - Nylon

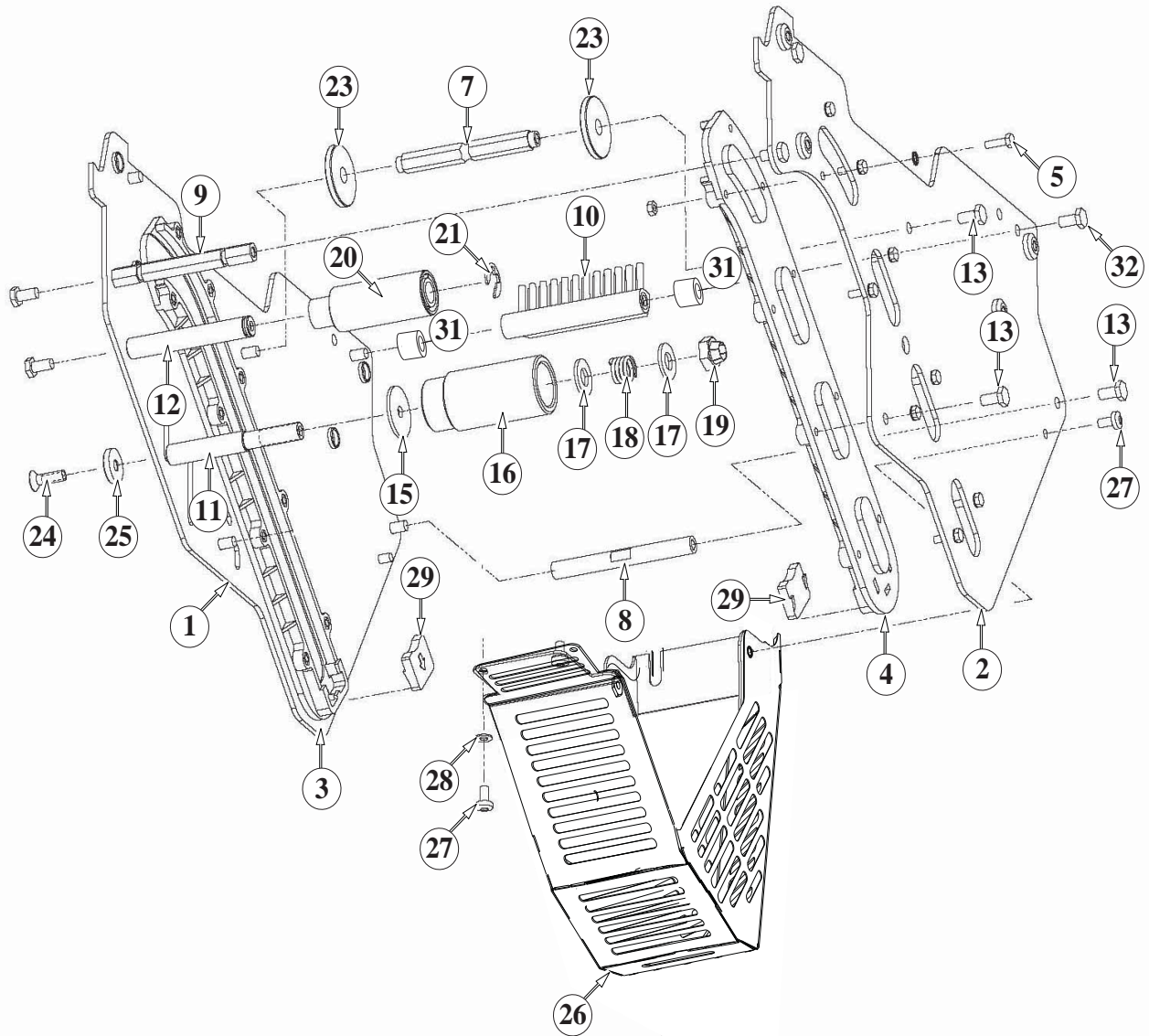

Figure 10931 – Lower Head

Figure 10931 – Lower Head

Ref. No.	3M Part No.	Description
10931-1	78-8137-3296-9	Frame – Tape Mount Lower Assembly
10931-2	78-8137-3297-7	Frame – Front Lower Assembly
10931-3	78-8068-4144-7	Guide – #2
10931-4	78-8068-4143-9	Guide – #1
10931-5	83-0002-7336-3	Screw – Hex Hd, M4 x 14
10931-6	78-8010-7416-8	Nut – Hex, M4
10931-7	78-8076-4735-5	Spacer – Spring
10931-8	78-8137-3309-0	Spacer – 10 x 10 x 115 mm
10931-9	78-8060-7939-4	Spacer – 10 x 115, W/Slots
10931-10	78-8060-7936-0	Brush Assembly
10931-11	78-8054-8796-0	Shaft – Tension Roller
10931-12	78-8054-8798-6	Shaft – Wrap Roller
10931-13	26-1003-5829-5	Screw – Hex Hd, M6 x 12
10931-15	78-8100-1009-6	Washer – Special
10931-16	78-8054-8817-4	Roller – Tension Bottom
10931-17	26-1004-5510-9	Washer – Plain, M10
10931-18	78-8052-6567-1	Spring – Compression
10931-19	78-8017-9077-1	Nut – Self Locking, M10 x 1
10931-20	78-8054-8799-4	Roller – Wrap
10931-21	26-1000-1613-3	Ring – Retaining, Tru-Arc #1-420-0120-100
10931-22	78-8076-4500-3	Stud – Mounting (not shown)
10931-23	78-8076-5242-1	Stop – Cut-Off Frame
10931-24	78-8060-8179-6	Screw – Flat Head Hex, M6 x 20
10931-25	78-8076-5477-3	Washer – Special /6.5 x 20 x 4
10931-26	78-8137-3310-8	Guard – Head
10931-27	78-8060-8087-1	Screw – M5 x 10
10931-28	78-8005-5741-1	Washer – Flat, M5
10931-29	78-8133-9615-3	Bumper
10931-30	78-8133-9606-2	Label – Threading, English Language
10931-31	78-8060-7937-8	Spacer 6.5 / 14 x 12.5
10931-32	78-8060-7938-6	Screw - Low Profile M6 x 25
10924-33	78-8076-4716-5	Star Washer 4mm

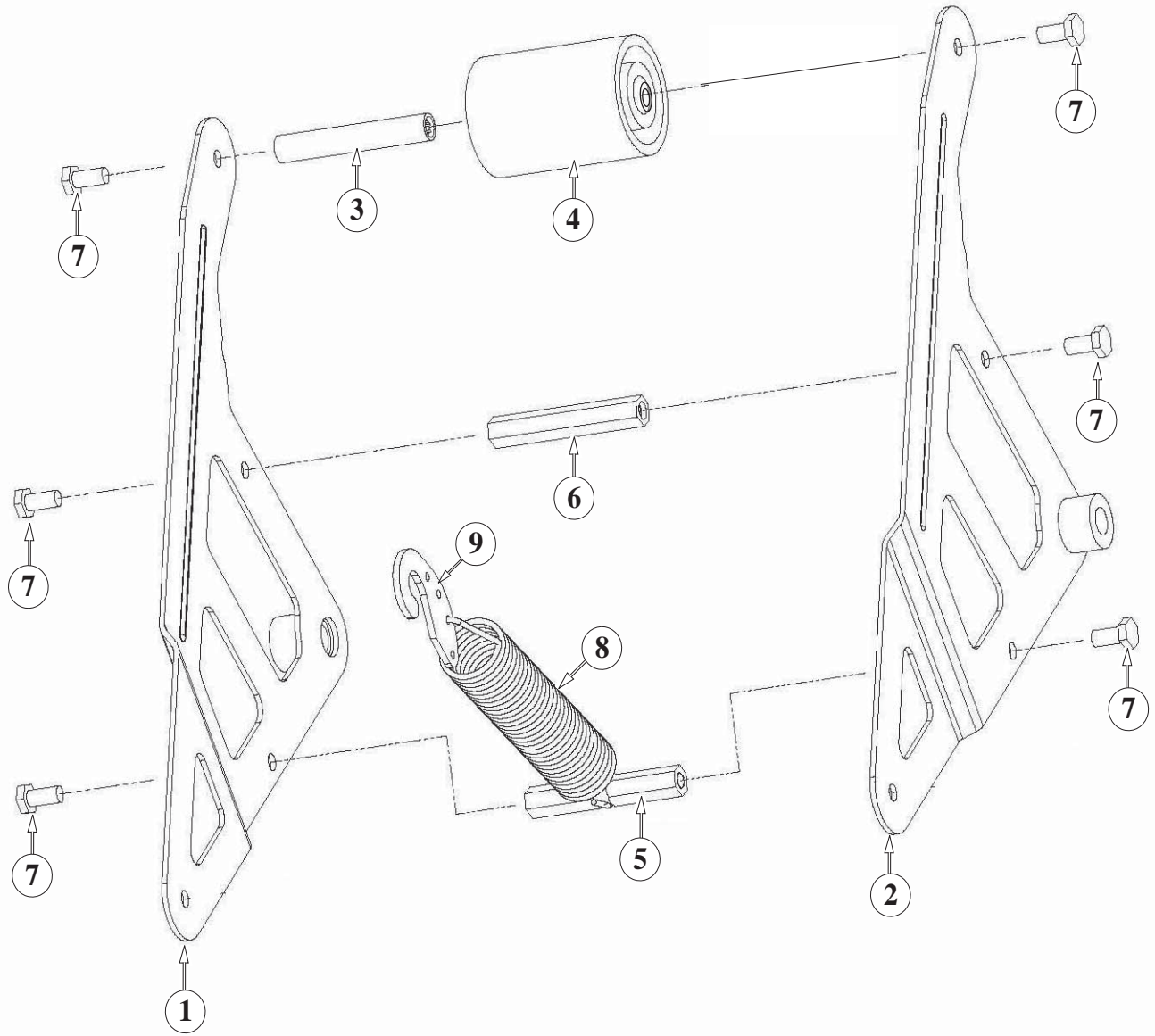

Figure 10927 – Lower Head

Figure 10927 – Lower Head

Ref. No.	3M Part No.	Description
10927-1	78-8137-3300-9	Buffing Arm – Sub Assembly
10927-2	78-8137-3301-7	Buffing Arm – Sub Assembly
10927-3	78-8091-0799-4	Shaft – 10 x 85, W/Hexagon
10927-4	78-8137-1397-7	Roller – Buffing
10927-5	78-8076-4739-7	Spacer – Spring
10927-6	78-8052-6580-4	Spacer
10927-7	26-1003-5829-5	Screw – Hex Hd, M6 x 12
10927-8	78-8137-3312-4	Spring – Lower (100 fpm)
10927-9	78-8070-1244-4	Holder – Spring

